

Ralph J. Stephenson, P.E., P.C.
Consulting Engineer
323 Hiawatha Drive
Mt. Pleasant, Michigan 48853
(517) 772 2537
March 15, 1992

91:37

Subject: Monitoring Report #1
First Colony Life Insurance Building Remodeling
Lynchburg, Virginia

Project #: 91:37

Disk #'s: 283 & 304

Dates of monitoring: March 3 and 4, 1992 (wd's 299 and 300)

Monitored from: Sht #LL - issue #3, dated December 3, 1991 (wd 236)
Sht #1-79 - issue #3, dated December 3, 1991 (wd 236)
Sht #3-79/68 ne - issue #3, dated December 3, 1991 (wd 236)
Sheet #T-79 - issue #3, dated December 3, 1991 (wd 236)
Sheet #2-79/68 - issue #3, dated December 3, 1991 (wd 236)
Sheet #1-68 - issue #3, dated December 3, 1991 (wd 236)
Sheet #T-68 - issue #3, dated December 3, 1991 (wd 236)

Start and move in dates from Issue #3 network models:

- Lower level started in December, 1991
completed 01/09/92 (wd 262)
- 1-79 started in December, 1991
to be complete 04/10/92 (wd 328)
- 3-79/68 ne started 12/03/91 (wd 236)
to be complete 04/22/92 (wd 336)
- T-79 started 01/13/92 (wd 263)
to be complete 05/13/92 (wd 351)
- 2-79/68 started in December, 1991
to be complete 05/18/92 (wd 354)
- 1-68 start 05/19/92 (wd 354)
to be complete 10/22/92 (wd 464)
- T-68 start 10/23/92 (wd 464)
to be complete 04/02/93 (wd 577)
- 3-68 e no issue #3 diagram prepared

Ralph J. Stephenson, P.E., P.C.
Consulting Engineer
323 Hiawatha Drive
Mt. Pleasant, Michigan 48853
(517) 772 2537
March 15, 1992

Start and move in dates from updated Issue #4 network models:

- Lower level work completed. 1st Colony moved in on 01/08/92 (261)
- 1-79 started in December, 1991
to be complete 06/09/92 (wd 369)

- 3-79/68 ne started 12/03/91 (wd 236)
to be complete 05/29/92 (wd 362)

- T-79 started 01/13/92 (wd 263)
to be complete 04/20/92 (wd 334)

- 2-79/68 started in December, 1991
to be complete 06/17/92 (375)

- 1-68 start 06/09/92 (wd 368)
to be complete 11/11/92 (wd 478)

- T-68 start 11/12/92 (wd 478)
to be complete 04/22/93 (wd 591)

- 3-68 e start 03/03/92 (wd 299)
to be complete - 06/08/92 (wd 368)

Actions taken:

- Inspected project with Mr. Steve Greene and Mr. Phil Jamerson
- Reviewed current project status relative to areas not yet in work
- Updated network models for areas
 - 1-79
 - 3-79/68 ne
 - T-79
 - 2-79/68
 - 1-68
 - T- 68
 - 3-68 e
- Prepared monitoring report

Summary

The main purpose of this session was to monitor the project, evaluate current

Ralph J. Stephenson, P.E., P.C.
Consulting Engineer
323 Hiawatha Drive
Mt. Pleasant, Michigan 48853
(517) 772 2537
March 15, 1992

status and update the network plans as required.

Work at the lower level (LL) was completed on January 8, 1992 (wd 261), one day ahead of the scheduled completion of January 9, 1992 (wd 262).

Currently four areas are in work. They are the 1979 addition 1st level (1-79), the 1979/1968 non executive (ne) addition 3rd level (3-79/68 ne), the 1979 addition Terrace Level (T-79), and the 1979/1968 addition 2nd level (2-79/68).

Level 1-79 interior rough work is nearly complete except for above floor sheet metal work and some above floor electrical and fire protection work. The new Issue #4 target date for completion of move into the 1-79 area is the pm of June 9, 1992 (wd 369).

Level 3-79/68 ne interior rough and finish work has been completed to where new ceiling work, finish painting and carpet could proceed. The new Issue #4 target date for move into the 3-79/68 area is the pm of May 29, 1992 (wd 362).

Work at the T-79 level has proceeded through most of the bulk rough work and the floor is now ready for finish painting, installation of carpet and completion of following interior finish work. The new Issue #4 target date for completion of move into the T-79 area is the pm of April 20, 1992 (wd 334) .

At the level 2-79/68 addition most rough interior work and some interior finish work is complete, and finish painting and carpet could start soon. This will be followed by remaining interior finish operations. The new Issue #4 target date for move into the 2-79/68 area is the pm of June 17, 1992 (wd 375).

As of the am of March 23, 1992 (wd 313) Mr. Jamerson estimates the approximate ahead or behind position at each area measured against the Issue #3 networks, dated December 3, 1992 (wd 236) as follows. These are projected lags based on progress expectations for the next few weeks.

First Level - 1979 addition (1-79)	20 working day lag
Third Level - 1979/68 addition (3-79/68 ne)	25 working day lag
Terrace Level - 1979 addition (T-79)	15 working days ahead
Second Level - 1979/68 addition (2-79/68)	10 working day lag

The updating of the networks to Issue #4, dated March 3, 1992 (wd 299) incorporated the revised sequencing and times into the network. The new starting dates as established for remaining areas are listed in tabulation and narrative above.

Ralph J. Stephenson, P.E., P.C.
Consulting Engineer
323 Hiawatha Drive
Mt. Pleasant, Michigan 48853
(517) 772 2537
March 15, 1992

Mr. Greene, Mr. Jamerson and I prepared a full set of updated or new network models for the entire project. These were reviewed at our meetings and finish printed copies left with Mr. Greene and Mr. Jamerson for their use and distribution. The updated data appears to be achievable. However these revised plans of action must be accompanied by continuous expediting of approvals and deliveries of critical materials. If additional lags are experienced, the causes for the lags must be identified immediately and corrections made if the project is to be completed as desired.

I suggest close front end procurement attention be given the 3-68 e area for the executive offices. This will be a critical area for predictable reoccupation.

I also recommend that the project be monitored again in from 1 1/2 to 3 months to insure that the plan of work is being followed and to assist to pick up any deteriorating trends in project progress. Continuous monitoring and analysis efforts should be maintained by the project team against the issue #4 networks.

I shall be in touch with Mr. Greene shortly to determine the advisability, and if needed, the timing of the next major monitoring and updating.

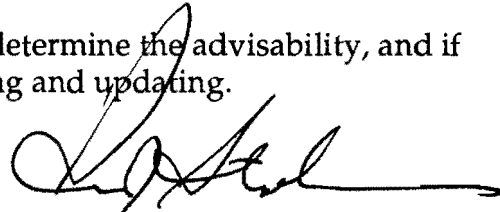

Ralph J. Stephenson, P. E.

/22/91
/22/91

**3rd Floor 79/68 non executive
(3-79/68 ne) Interior work**

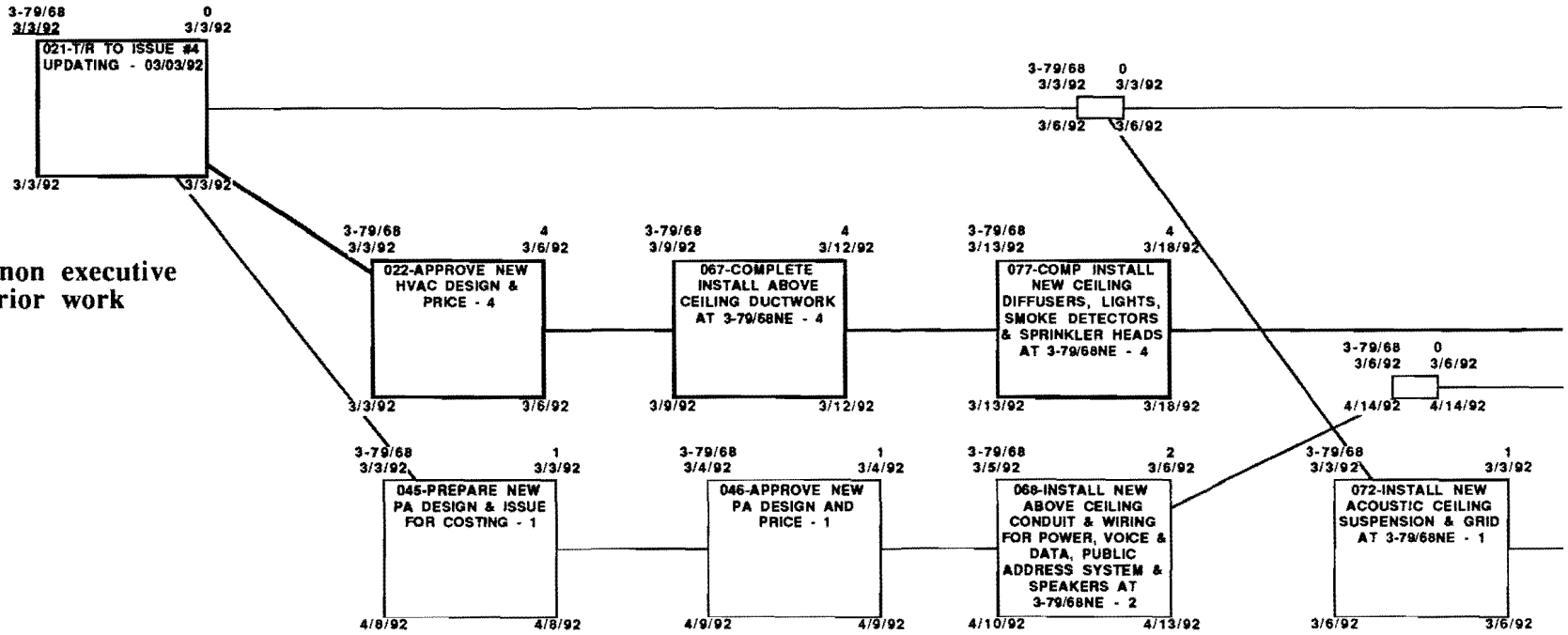

Location Duration
Early start Early finish

3-79/68 1
3/3/91 3/4/91

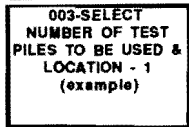

3/4/91 3/4/91

Late start Late finish

- Activity number
- Activity description
- Activity estimated duration in elapsed working days

Reserved Activity Numbers

017 to 040
046
047
048
049
045 050

ACTIVITY KEY

LAN 017
HAN 108

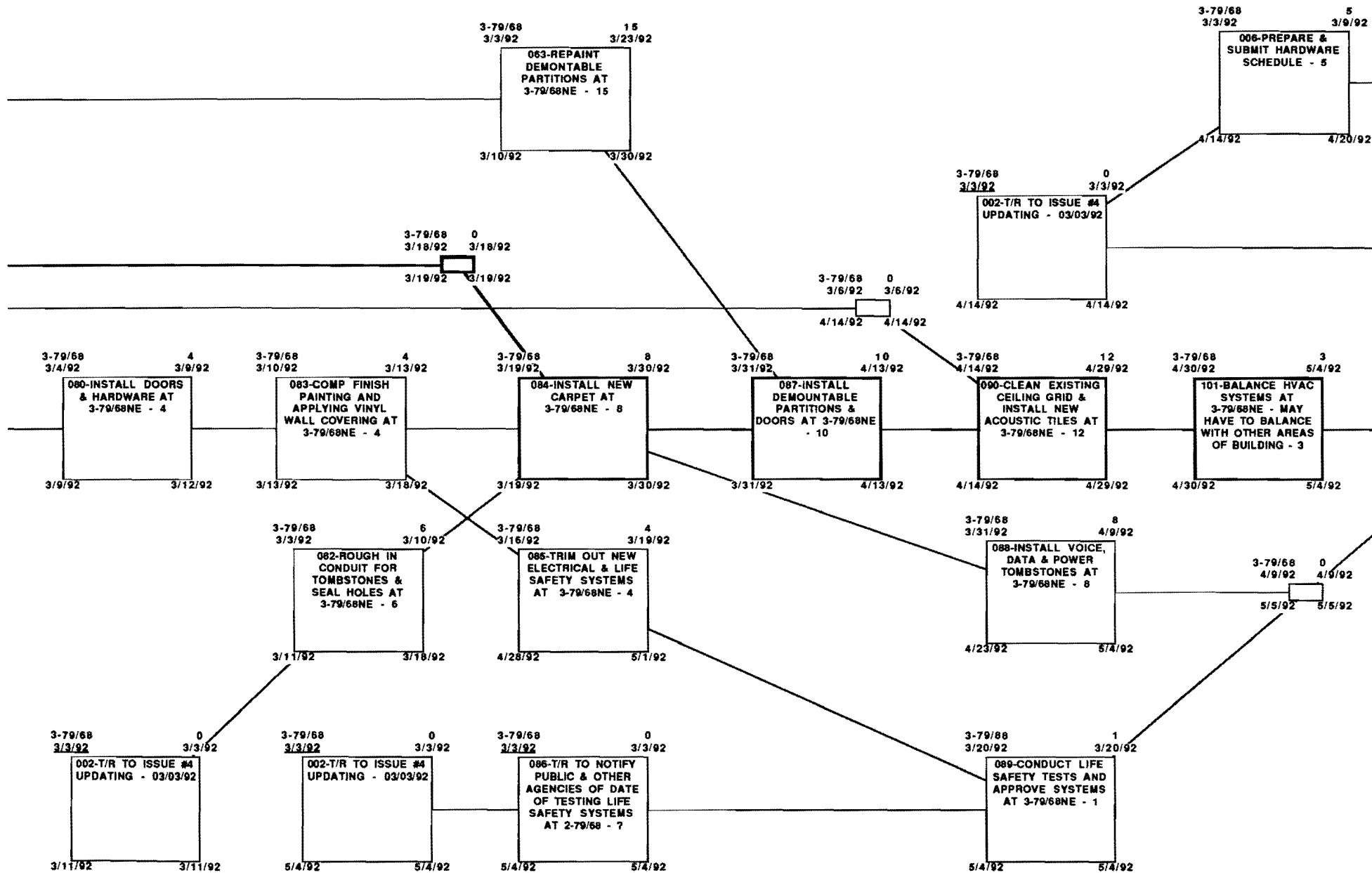

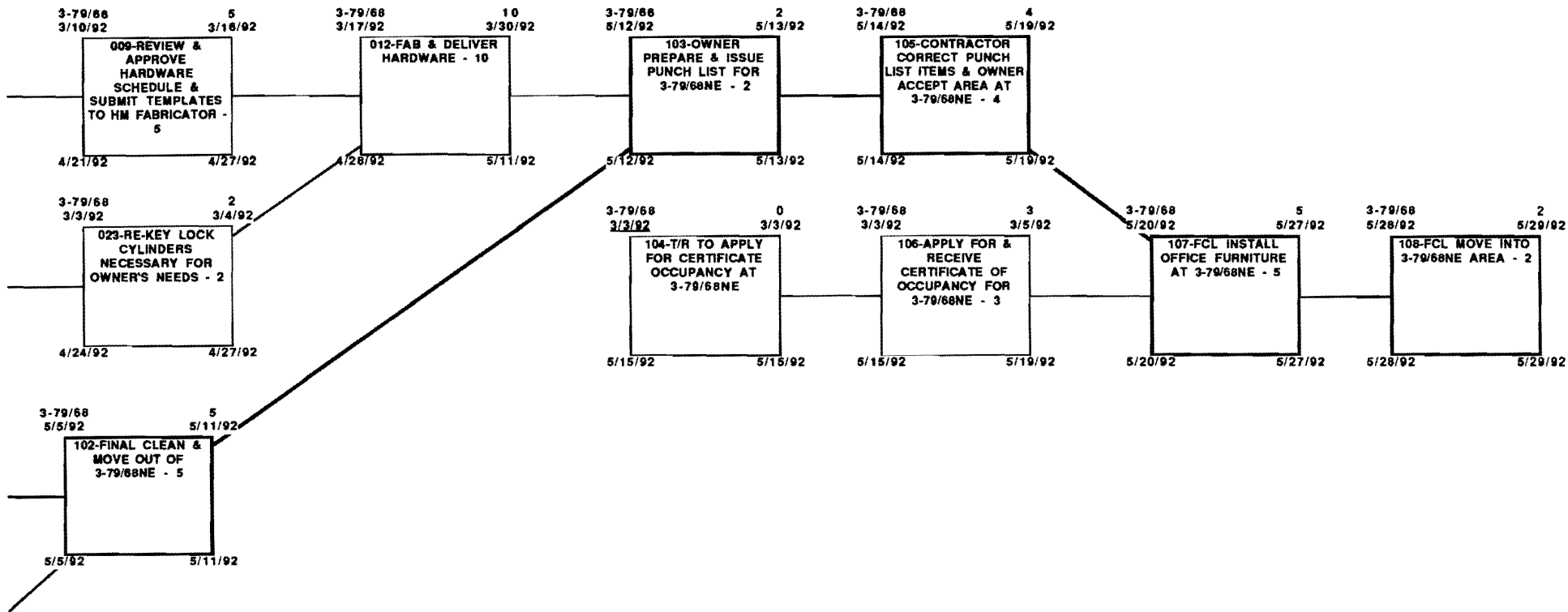

3rd Floor 79/68 non executive
(3-79/68 ne) Interior work

NETWORK MODEL FOR FIRST COLONY LIFE INSURANCE COMPANY OFFICE ADDITION Lynchburg, Virginia

Issue #1 - October 9, 1991
Issue #2 - October 22, 1991
Issue #3 - December 3, 1991
Issue #3 - monitored 03/03/92
Issue #4 - March 3, 1992
i4sht#3-79/68 ne
disk 304

H. J. Construction Joint Venture
Lynchburg, Virginia 24506

Ralph J. Stephenson PE PE
Consulting Engineer
323 Hiawatha Drive
Mt. Pleasant, Michigan 48853
ph 517 772 2537

Terrace 79 (T-79)
Interior work

1/22/91

1/22/91

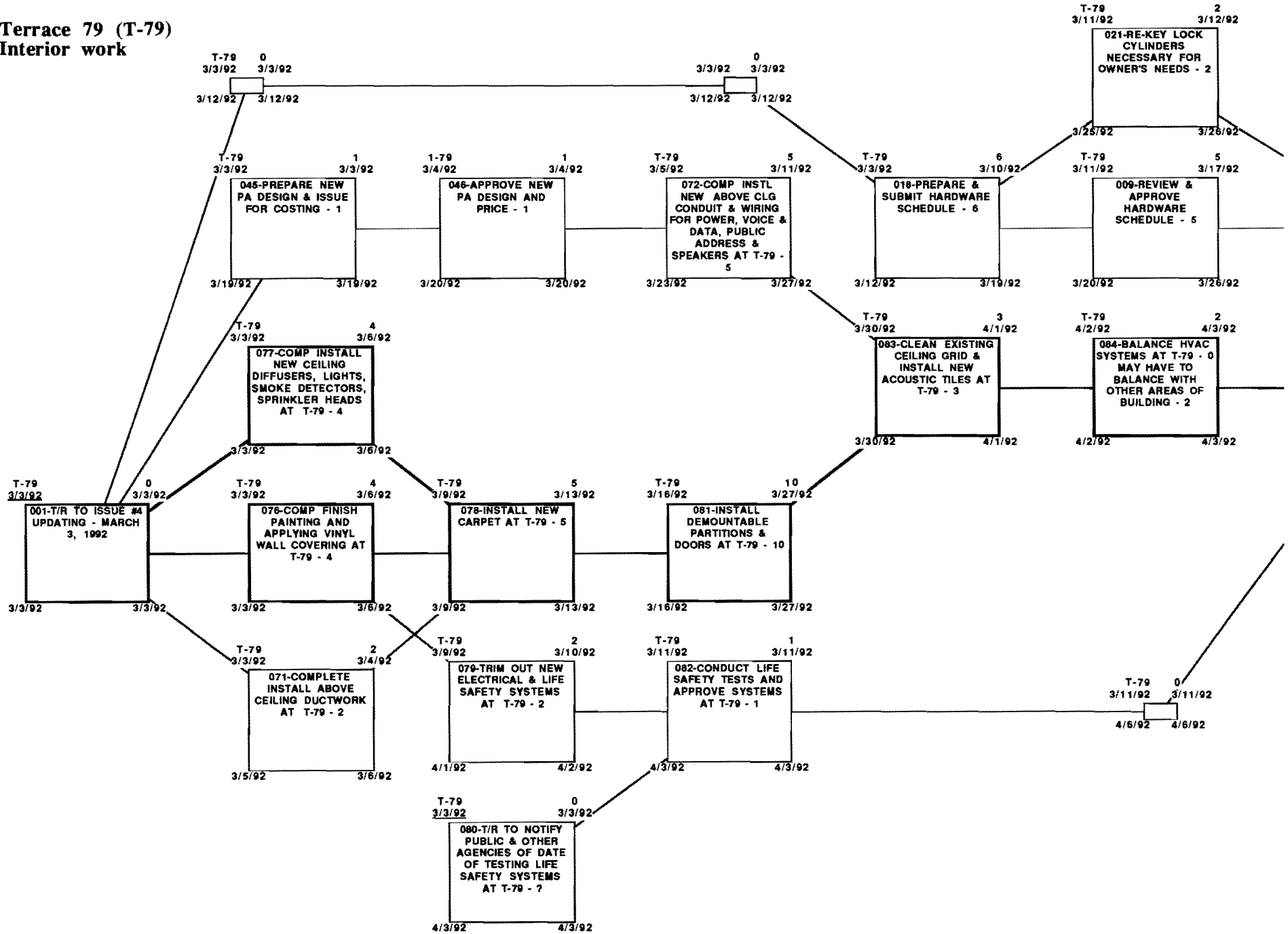

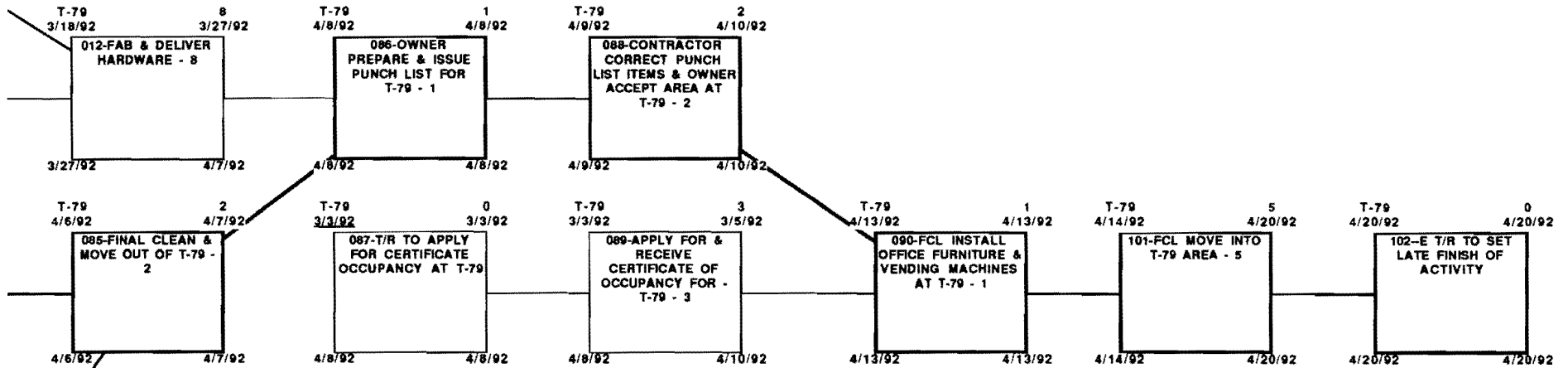

Terrace 79 (T-79)
Interior work

NETWORK MODEL FOR FIRST COLONY LIFE INSURANCE COMPANY OFFICE ADDITION Lynchburg, Virginia

H. J. Construction Joint Venture
Lynchburg, Virginia 24506

Ralph J. Stephenson PE PE
Consulting Engineer
323 Hiawatha Drive
Mt. Pleasant, Michigan 48853
ph 517 772 2537

Location Duration
Early start Early finish

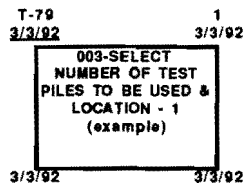

- Activity number
- Activity description
- Activity estimated duration in elapsed working days

Reserved Activity Numbers

017 to 040
041 046
042 047
043 048
044 049
045 050

Issue #1 - October 9, 1991
Issue #2 - October 22, 1991
Issue #3 - December 3, 1991
Issue #4 - March 3, 1992
idsh#T-79
disk 304

ACTIVITY KEY

lan 001
han 101

2nd Floor 79/68 (2-79/68)
Interior work

/22/91

/22/91

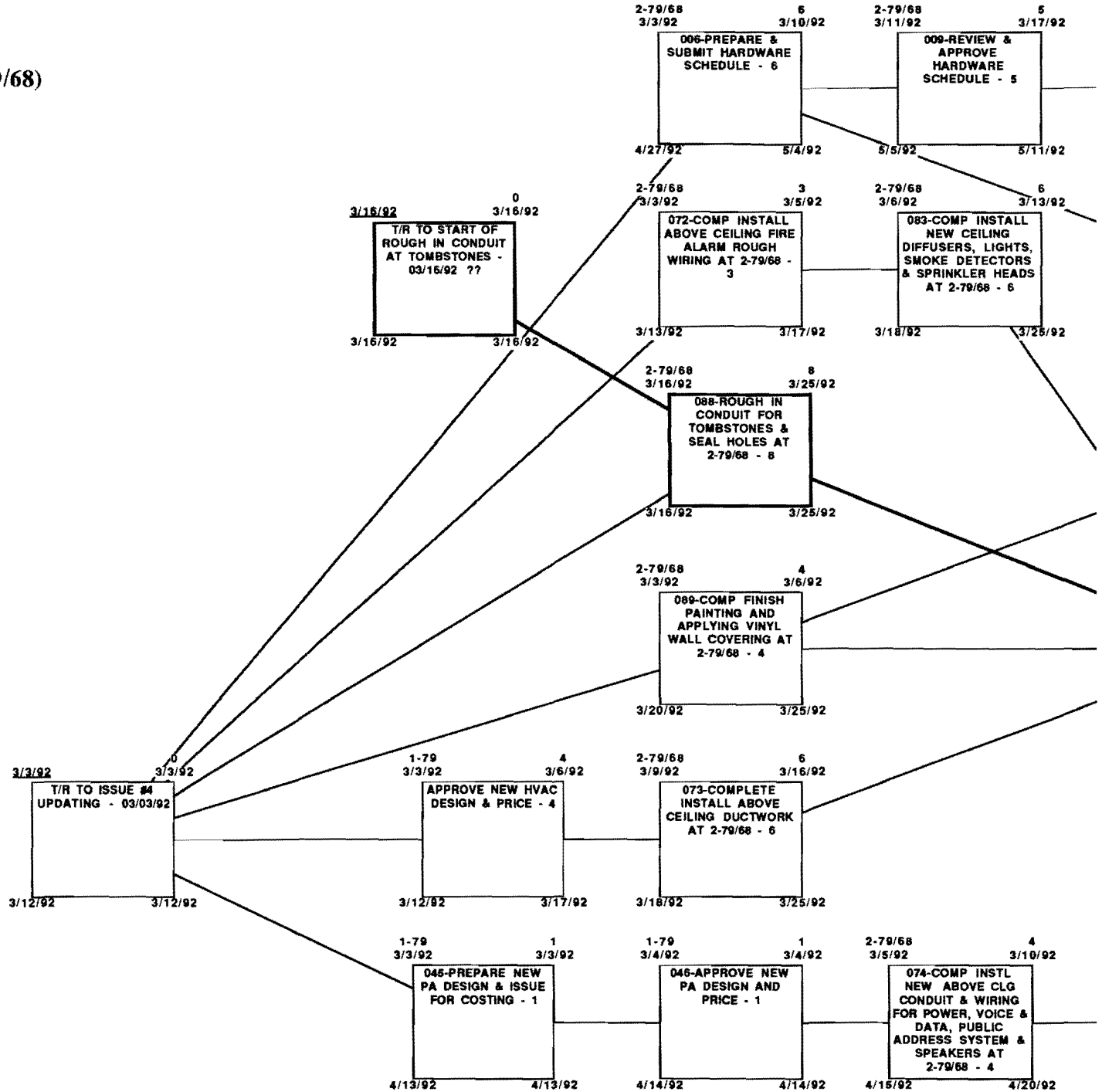

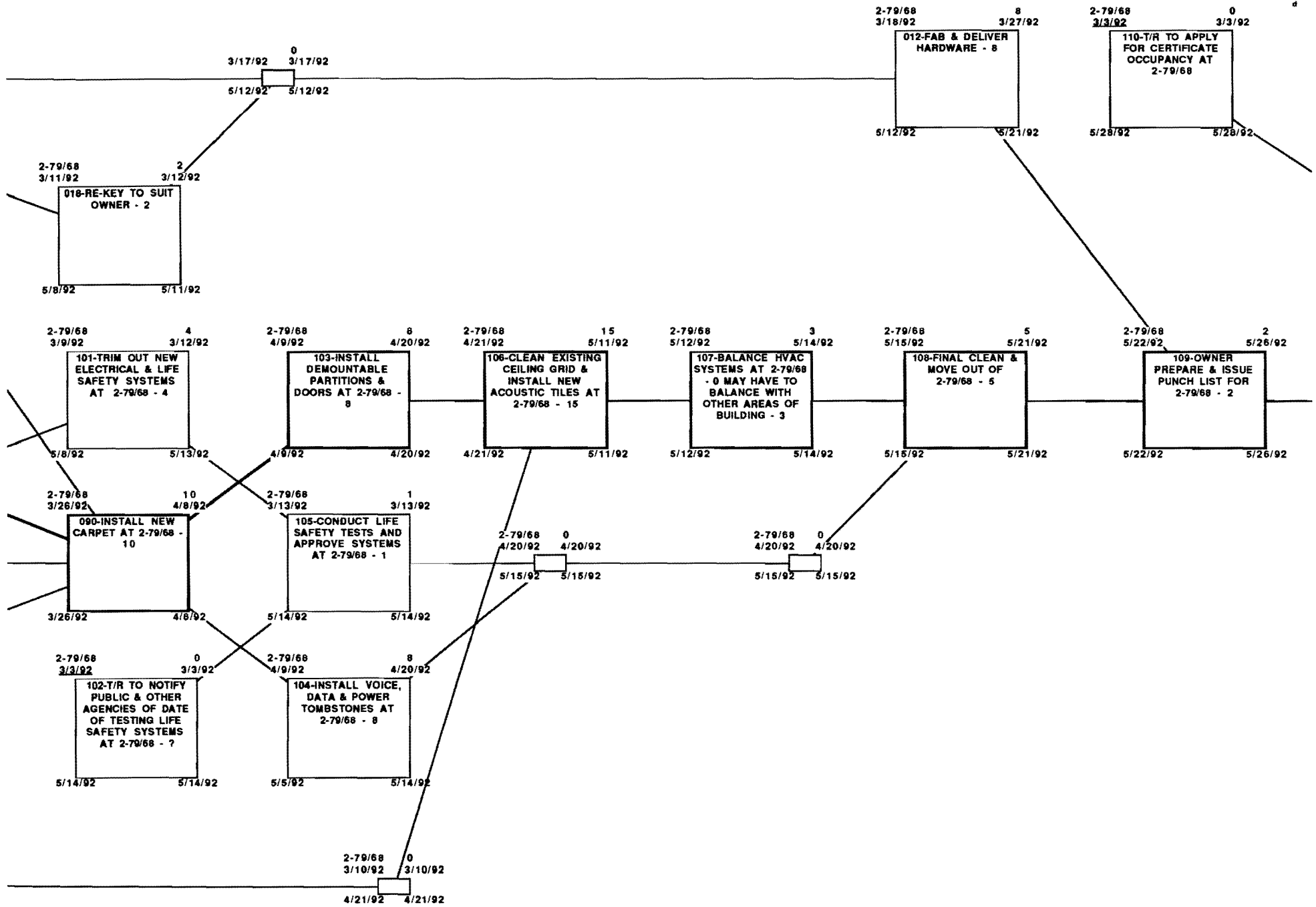

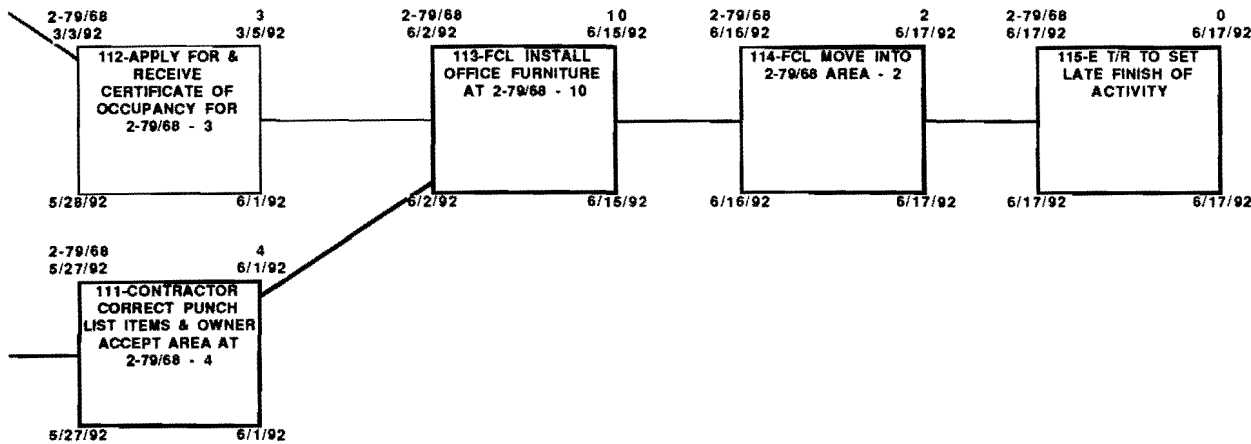

2nd Floor 79/68 (2-79/68)
Interior work

NETWORK MODEL FOR FIRST COLONY LIFE INSURANCE COMPANY OFFICE ADDITION Lynchburg, Virginia

H. J. Construction Joint Venture
Lynchburg, Virginia 24506

Ralph J. Stephenson PE PE
Consulting Engineer
323 Hiawatha Drive
Mt. Pleasant, Michigan 48853
ph 517 772 2537

Location Duration
Early start Early finish

2-79/68 1
10/22/91 10/22/91

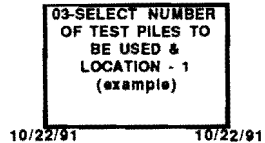

- Activity number
- Activity description
- Activity estimated duration in elapsed working days

Issue #1 - October 9, 1991
Issue #2 - October 22, 1991
Issue #3 - December 3, 1991
Issue #3 - monitored 03/03/92
Issue #4 - March 3, 1992
i4sht#2-79/68
disk 304

Reserved Activity Numbers

- 017 to 040
- 041 046
- 042 047
- 043 048
- 044 049
- 045 050
- LAN 001
- HAN 115

Late start Late finish

ACTIVITY KEY

1st Floor 68 (1-68)
Interior work

/22/91

/22/91

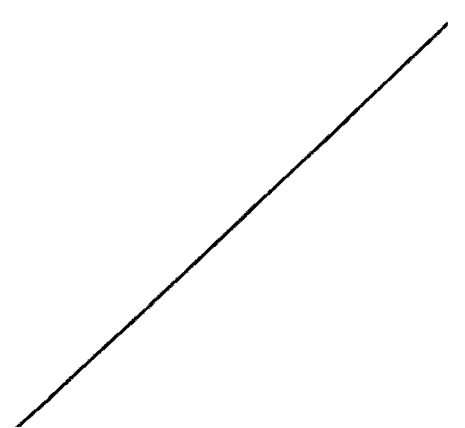

1-68 15
6/16/92 7/7/92

062-REPAINT
DEMONTABLE
PARTITIONS AT 1-68
- 15

9/3/92 9/24/92

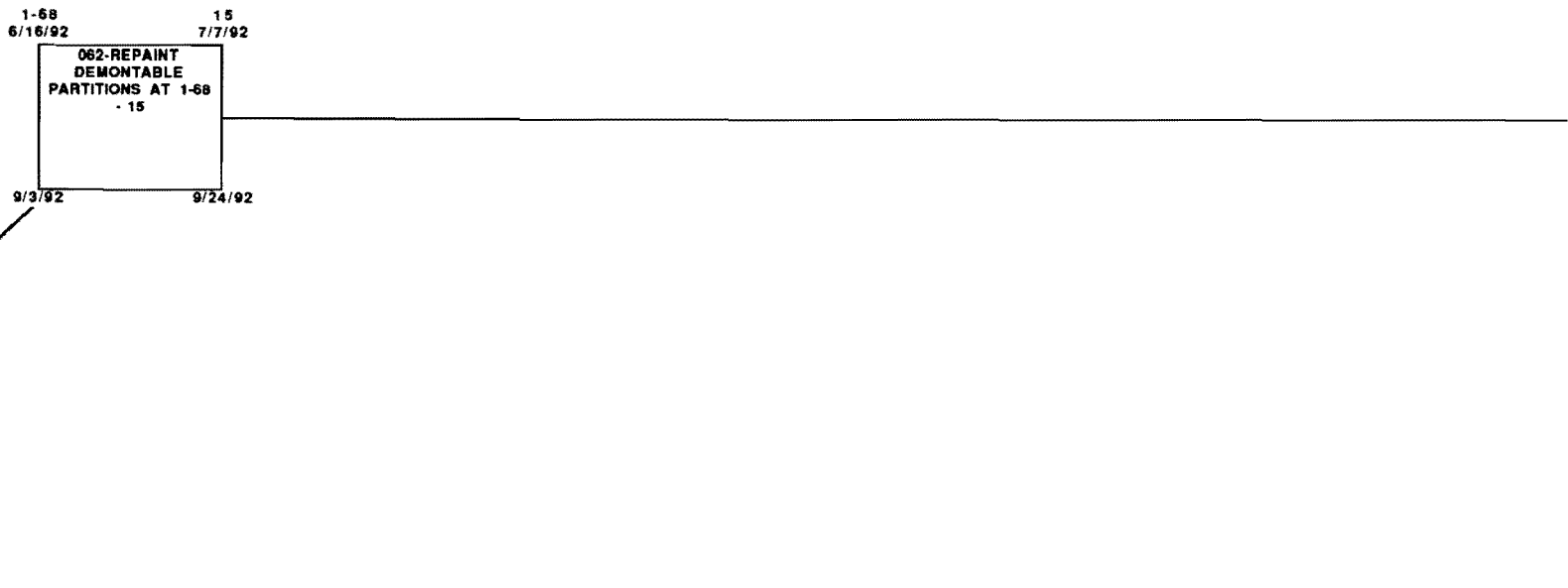

1-68 3
7/30/92 8/3/92

066-INSTALL ABOVE
CEILING FIRE ALARM
ROUGH WIRING AT
1-68 - 3

8/19/92 8/21/92

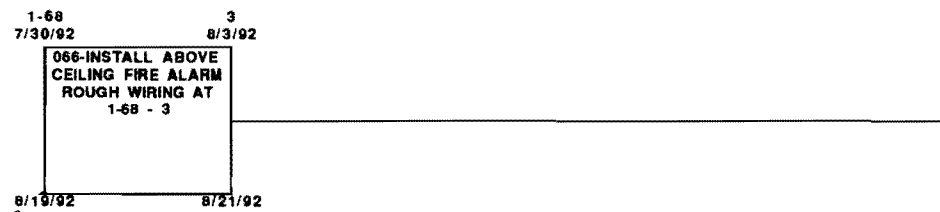

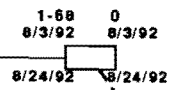
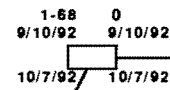
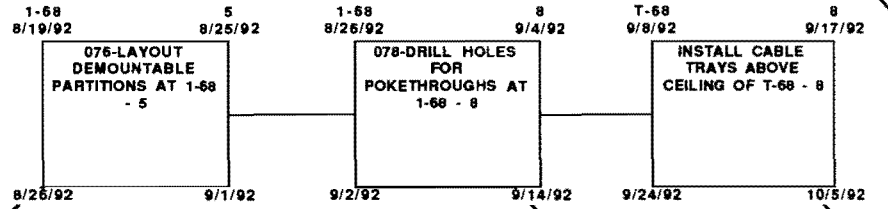
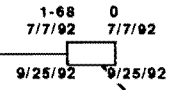
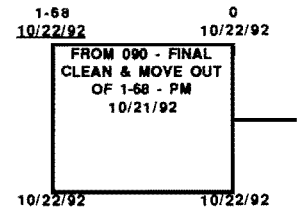

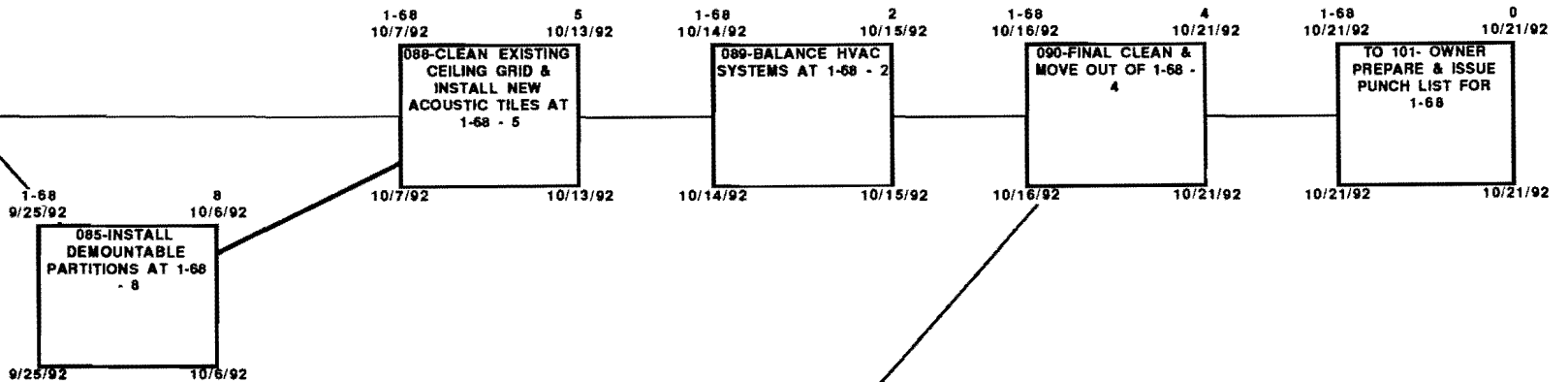
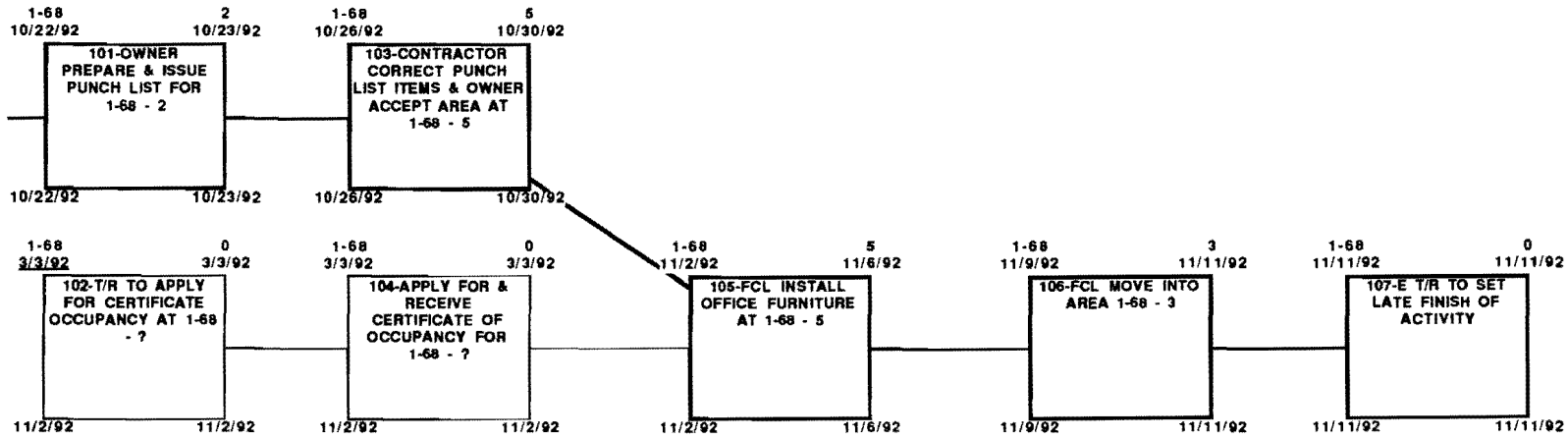

Note: Phase 2 starts after Phase 1 area 2-78/69 is occupied on pm 06/08/92

Should be per 6/17/92 (375)

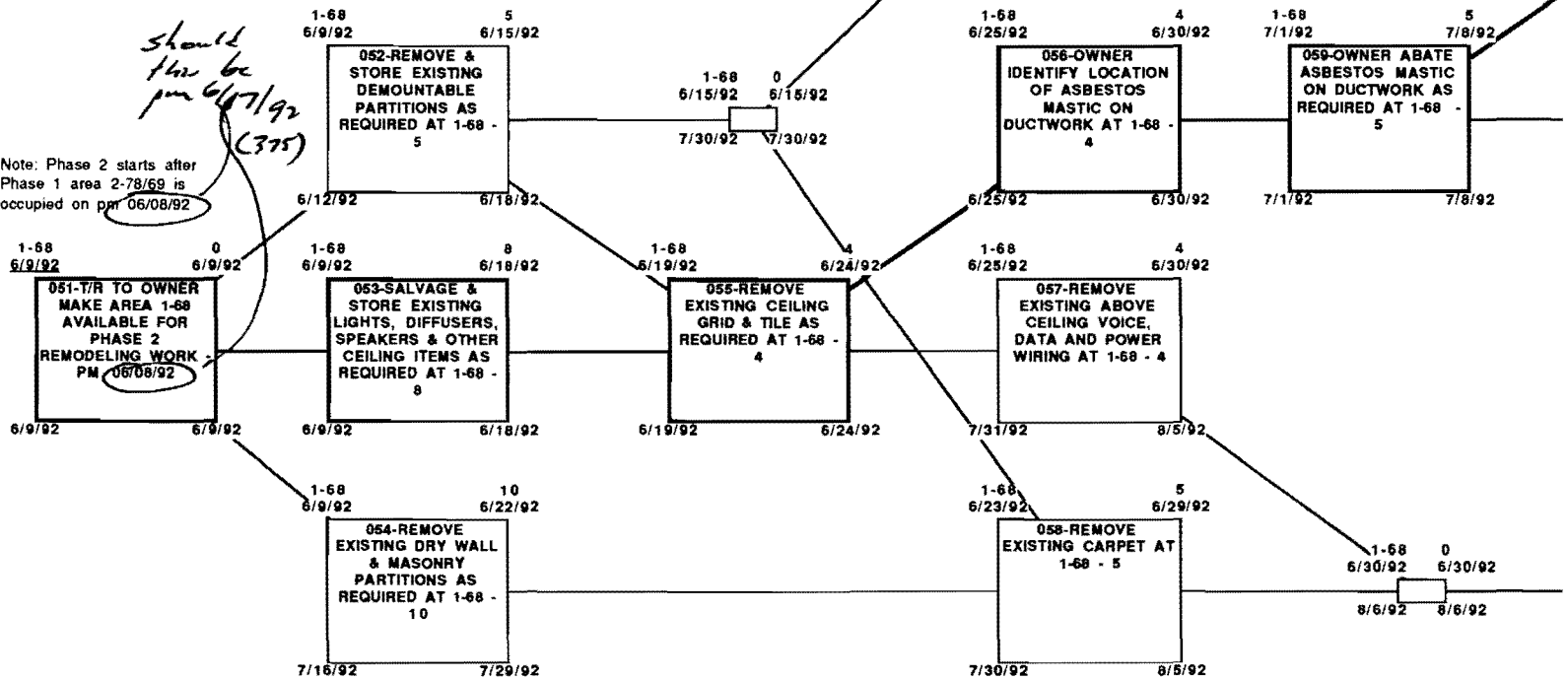

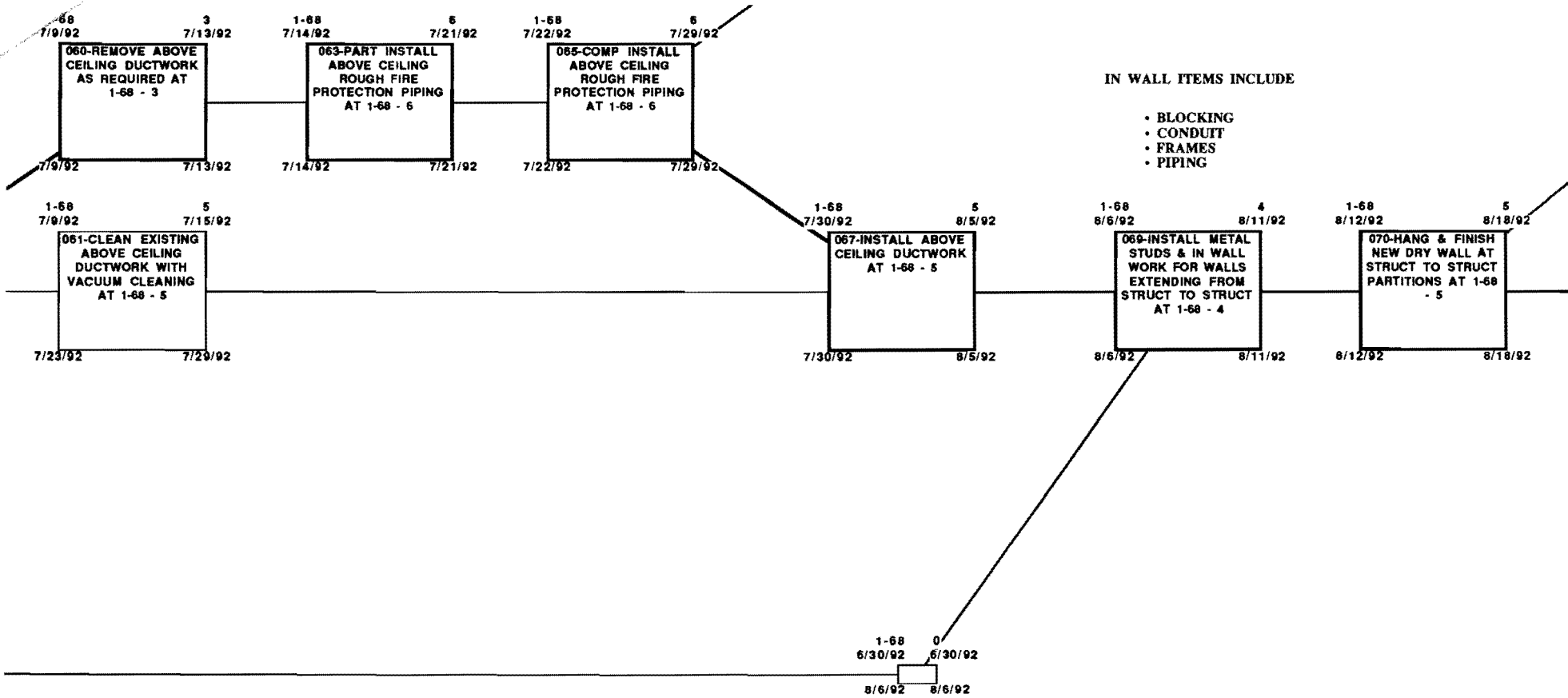

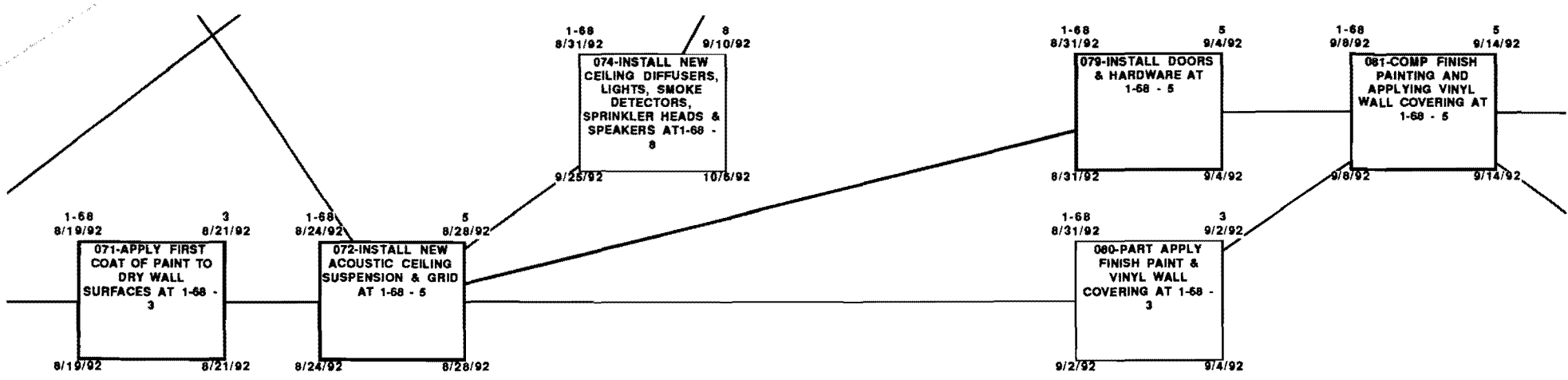

1-68 8/31/92 8 9/10/92

074-INSTALL NEW CEILING DIFFUSERS, LIGHTS, SMOKE DETECTORS, SPRINKLER HEADS & SPEAKERS AT 1-68 - 8

9/25/92 10/6/92

1-68 8/31/92 5 9/4/92

079-INSTALL DOORS & HARDWARE AT 1-68 - 5

8/31/92 9/4/92

1-68 9/8/92 5 9/14/92

081-COMP FINISH PAINTING AND APPLYING VINYL WALL COVERING AT 1-68 - 5

9/8/92 9/14/92

1-68 8/19/92 3 8/21/92

071-APPLY FIRST COAT OF PAINT TO DRY WALL SURFACES AT 1-68 - 3

8/19/92 8/21/92

1-68 8/24/92 5 8/28/92

072-INSTALL NEW ACOUSTIC CEILING SUSPENSION & GRID AT 1-68 - 5

8/24/92 8/28/92

1-68 8/31/92 3 9/2/92

080-PART APPLY FINISH PAINT & VINYL WALL COVERING AT 1-68 - 3

9/2/92 9/4/92

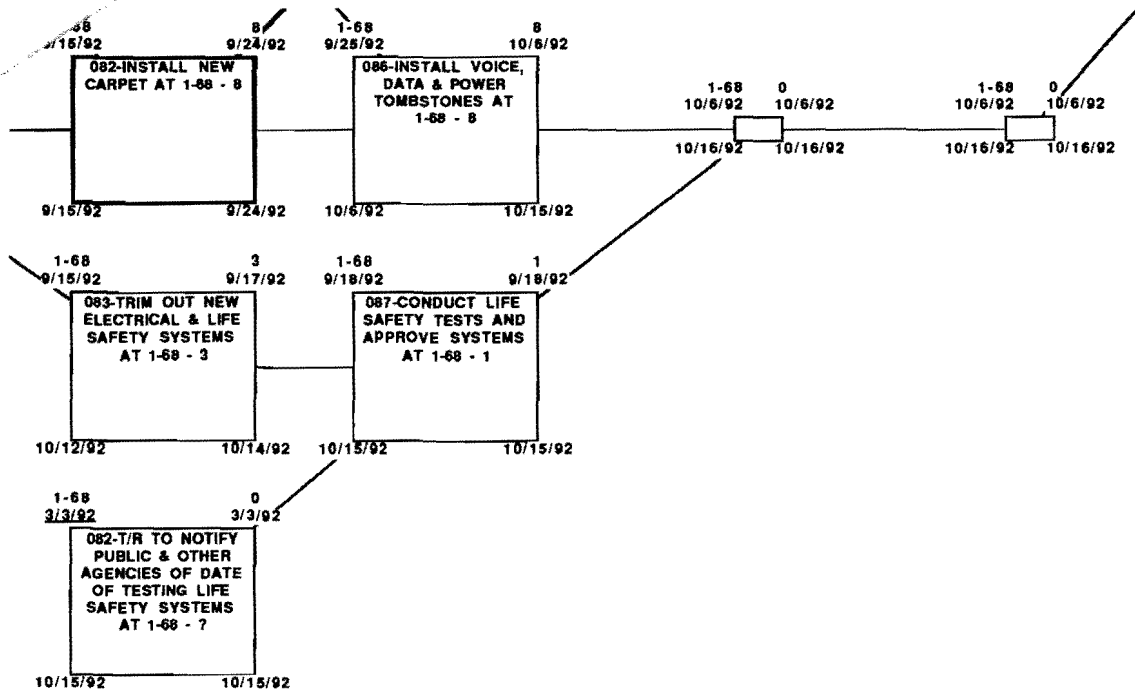

Location Duration
 Early start Early finish

1-68 1
 10/22/91 10/22/91

03-SELECT NUMBER
 OF TEST PILES TO
 BE USED &
 LOCATION - 1
 (example)

10/22/91 10/22/91

Late start Late finish

- Activity number
- Activity description
- Activity estimated duration in elapsed working days

Reserved Activity Numbers

017 to 040
 041 046
 042 047
 043 048
 044 049
 045 050

LAN 001
 HAN 107

Issue #1 - not issued
 Issue #2 - October 22, 1991
 Issue #3 - December 3, 1991
 Issue #4 - March 3, 1992
 i4sh#1-68 int work
 disk #304

1st Floor 68 (1-68)
 Interior work
**NETWORK MODEL FOR FIRST
 COLONY LIFE INSURANCE
 COMPANY OFFICE ADDITION
 Lynchburg, Virginia**

H. J. Construction Joint Venture
 Lynchburg, Virginia 24506

Ralph J. Stephenson PE PE
 Consulting Engineer
 323 Hiawatha Drive
 Mt. Pleasant, Michigan 48853
 ph 517 772 2537

ACTIVITY KEY

Terrace 68 (T-68)

Interior work

/22/01

/22/01

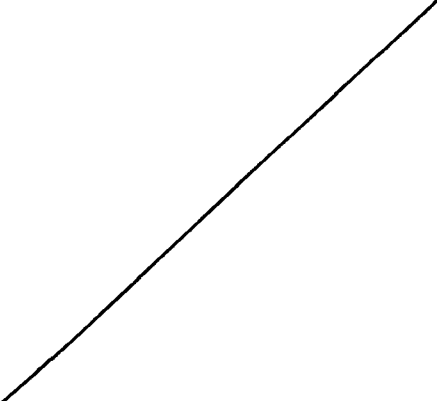

T-68 15
11/19/92 12/10/92

062-REPAINT
DEMONTABLE
PARTITIONS AT T-68
- 15

2/15/93 3/5/93

T-68 3
12/30/92 1/4/93

066-INSTALL ABOVE
CEILING FIRE ALARM
ROUGH WIRING AT
T-68 - 3

1/25/93 2/2/93

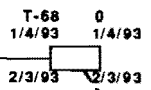
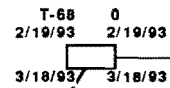
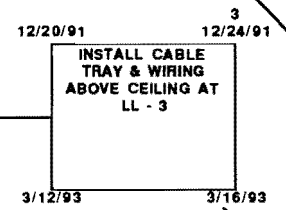
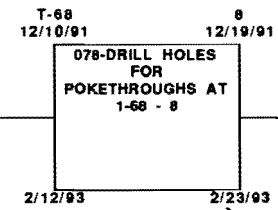
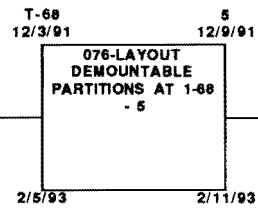
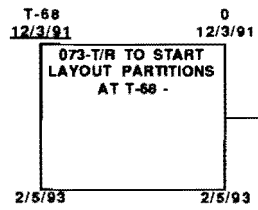
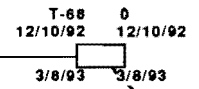
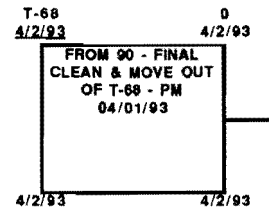

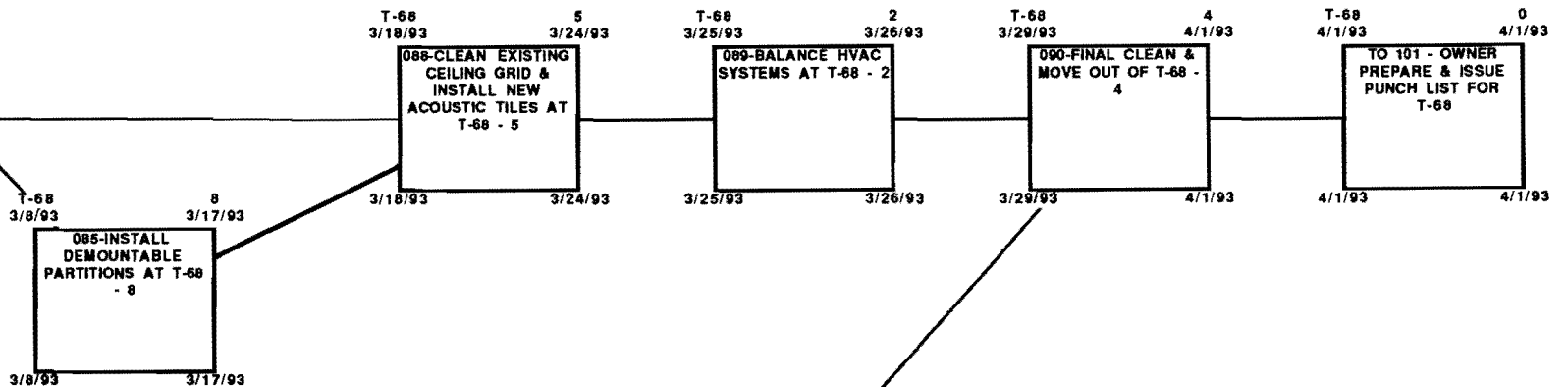
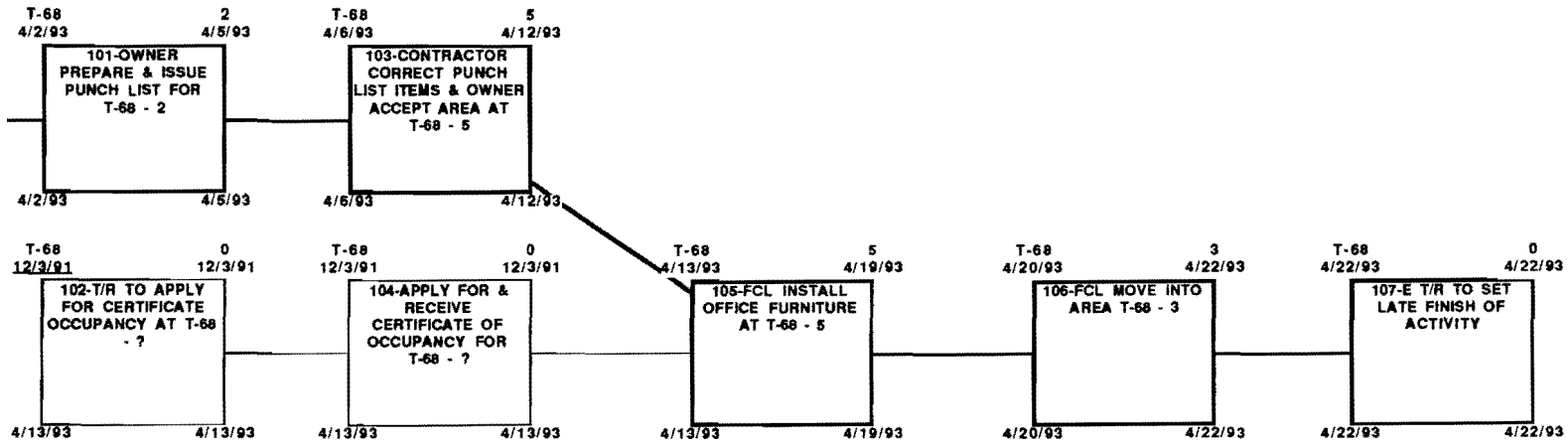

Note: Phase 3 starts after Phase 2 area 1-68 is occupied on PM 11/11/92

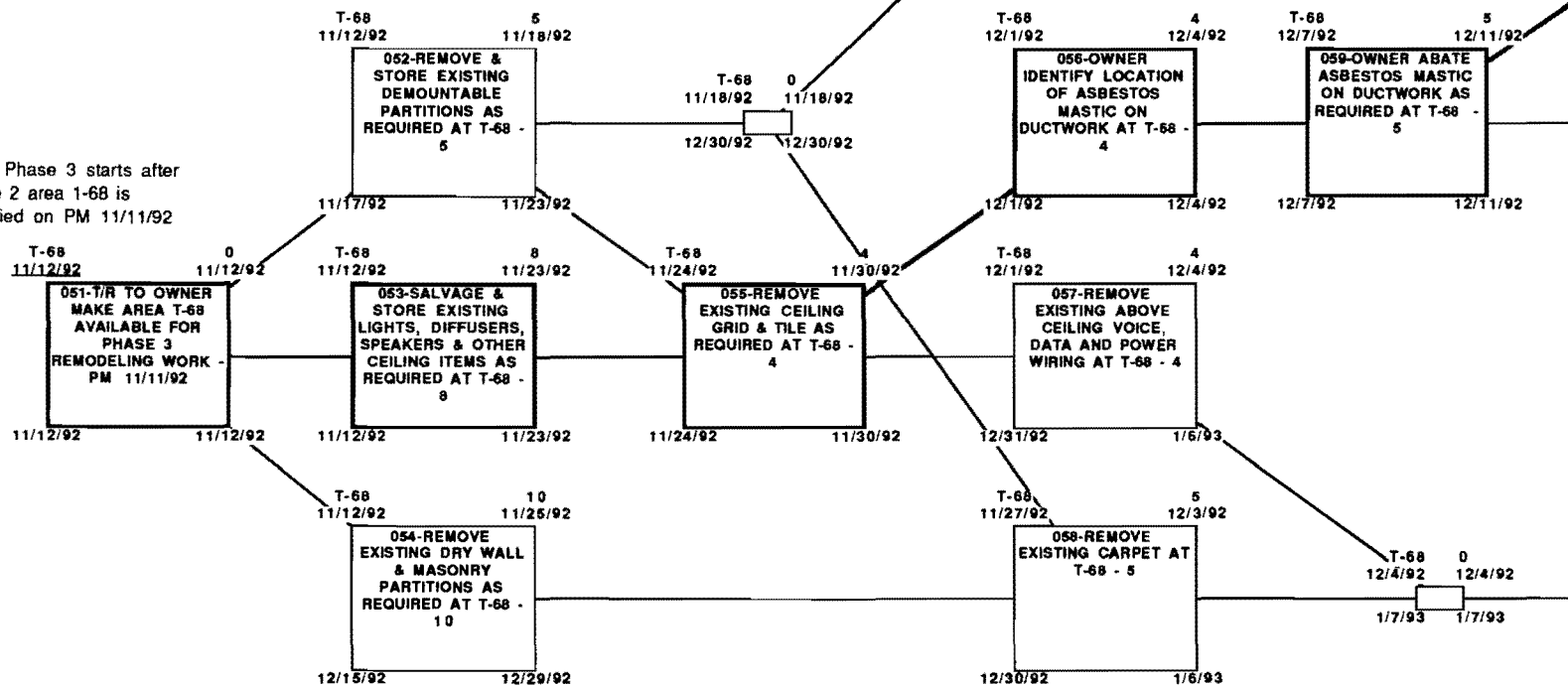

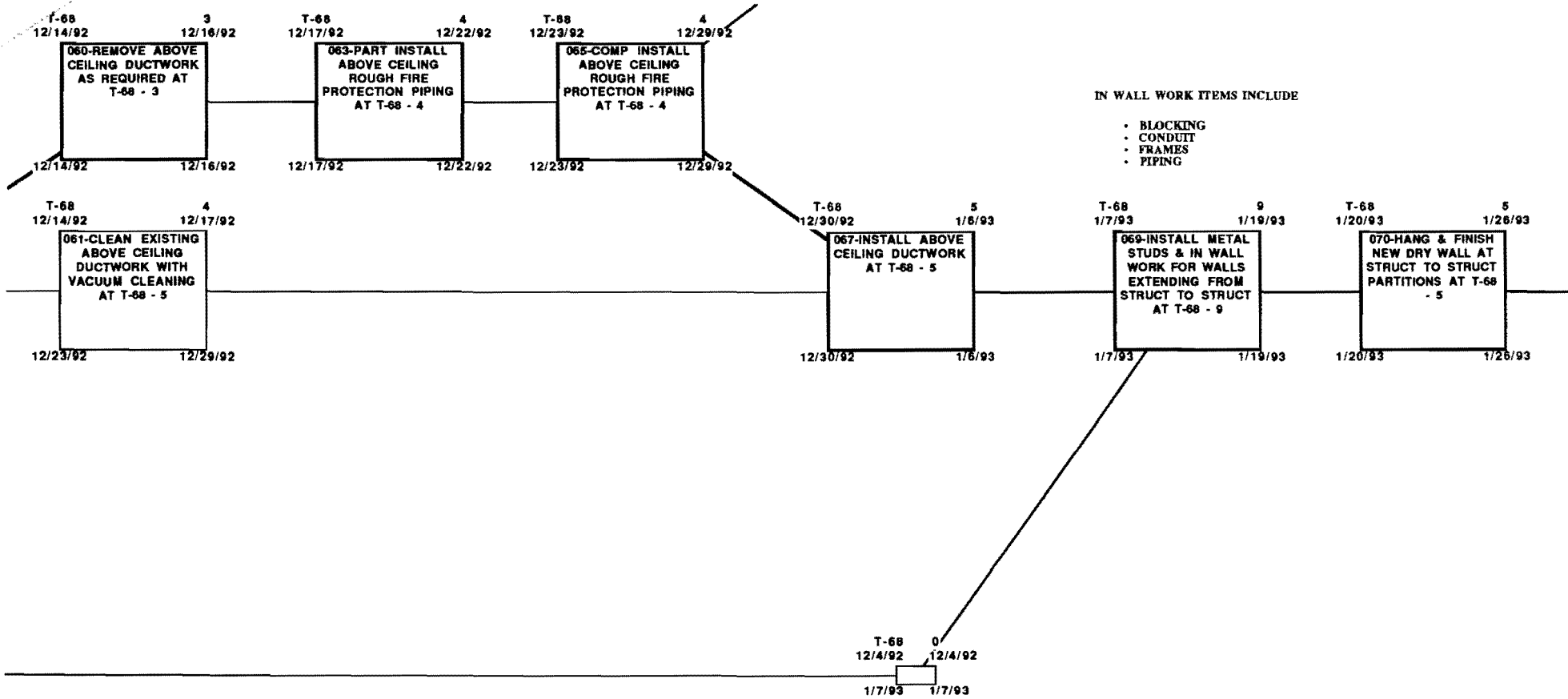

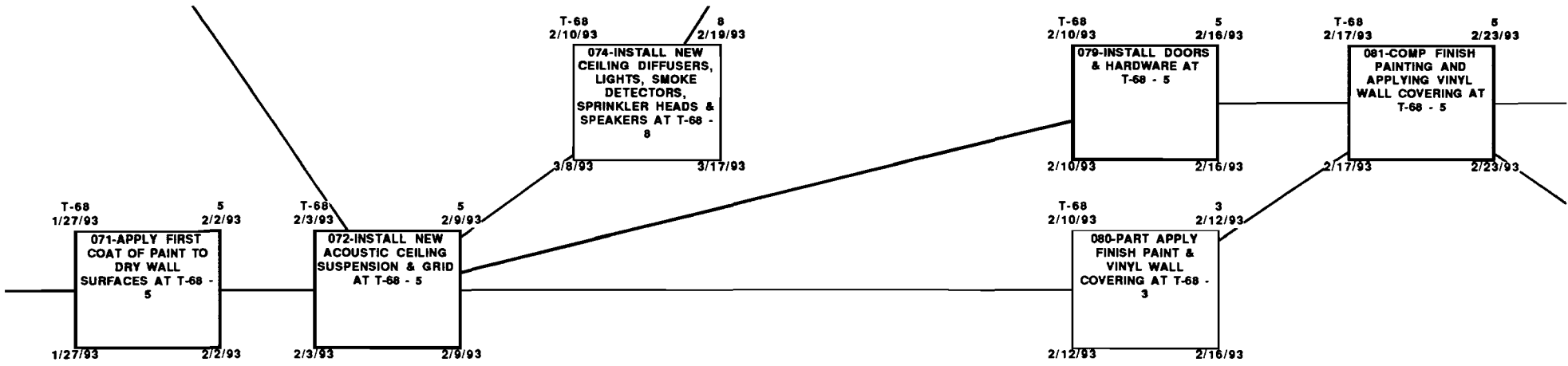

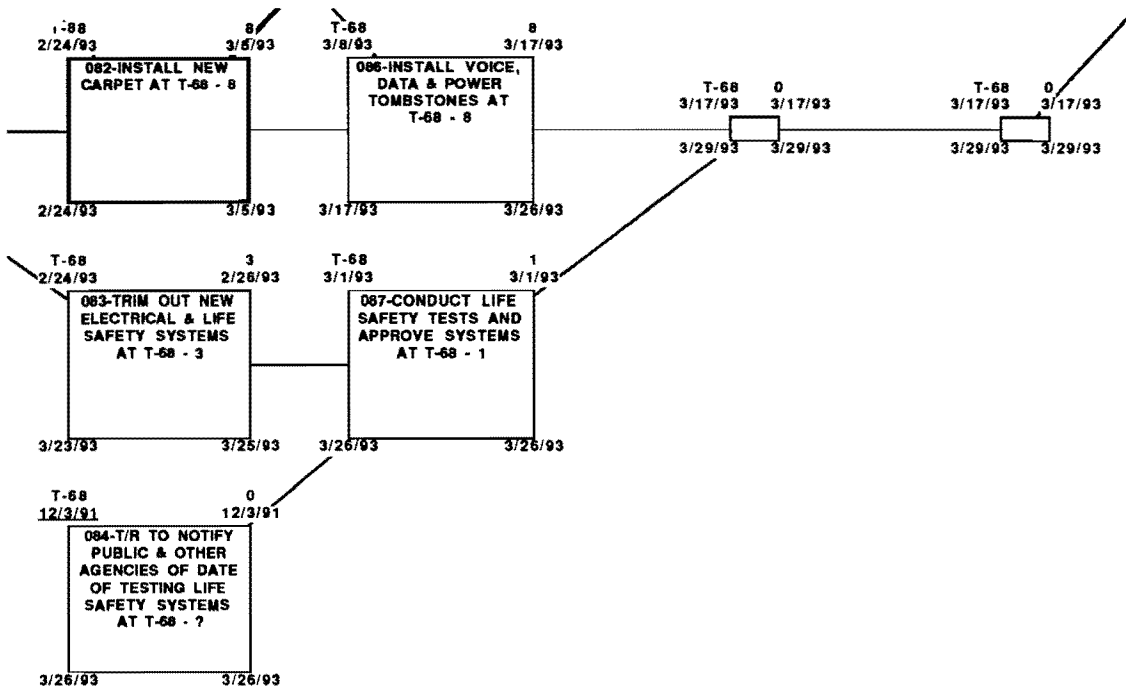

Location Duration
Early start Early finish

T-68 1
10/22/91 10/22/91

03-SELECT NUMBER OF TEST PILES TO BE USED & LOCATION - 1 (example)
10/22/91 10/22/91

Late start Late finish

- Activity number
- Activity description
- Activity estimated duration in elapsed working days

Reserved Activity Numbers

017 to 040
041 046
042 047
043 048
044 049
045 050

LAN 001
HAN 107

- Issue #1 - not issued
- Issue #2 - October 22, 1991
- Issue #3 - December 3, 1991
- Issue #4 - March 3, 1992
- i3sh4#T-68 int work disk #283

~~NE~~ Terrace T-68. Interior work. **MODEL FOR FIRST COLONY LIFE INSURANCE COMPANY OFFICE ADDITION Lynchburg, Virginia**

H. J. Construction Joint Venture
Lynchburg, Virginia 24506

Ralph J. Stephenson PE PE
Consulting Engineer
323 Hiawatha Drive
Mt. Pleasant, Michigan 48853
ph 517 772 2537

ACTIVITY KEY

**3rd Floor 68 executive
(3-68 e) Interior work**

/22/91
/22/91

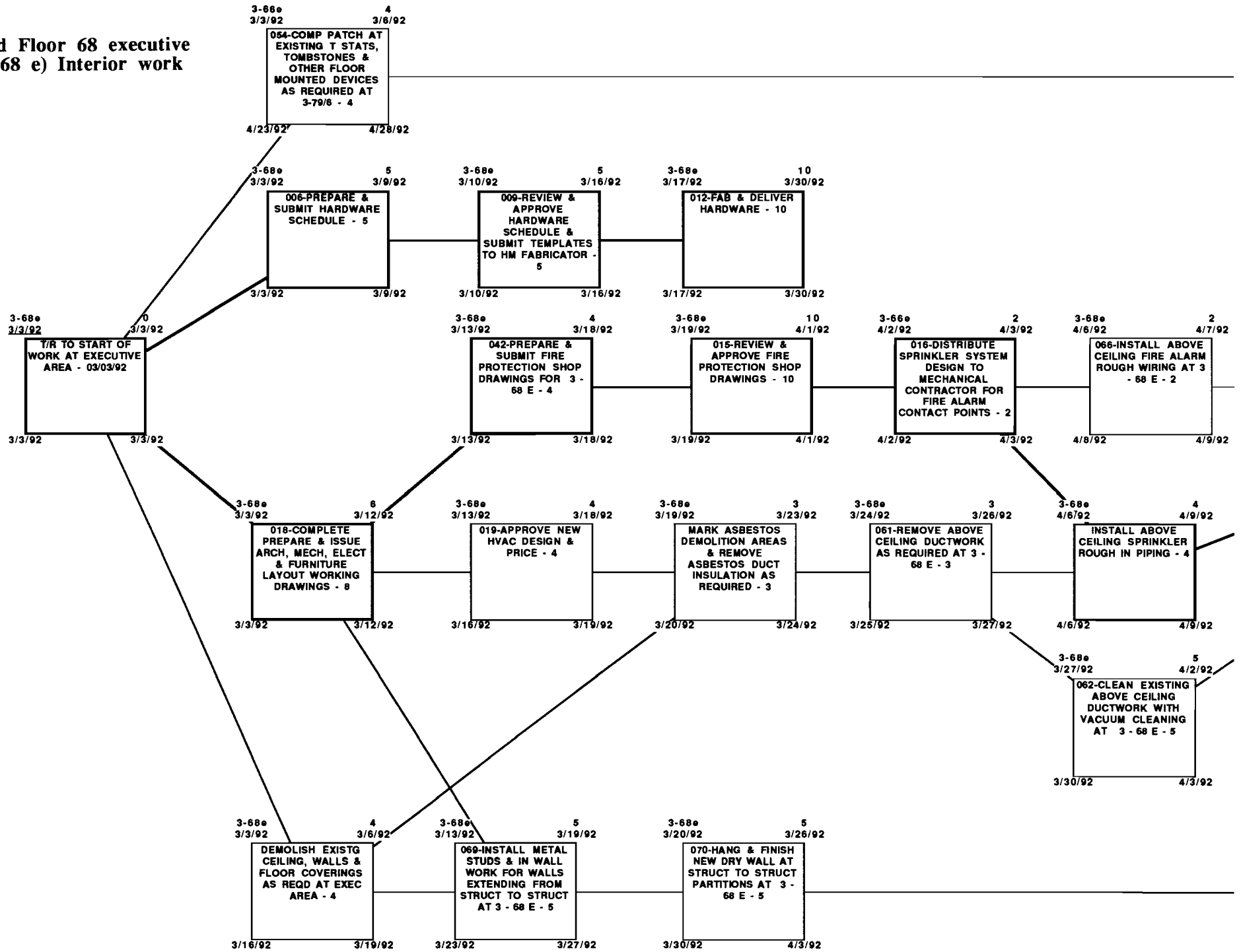

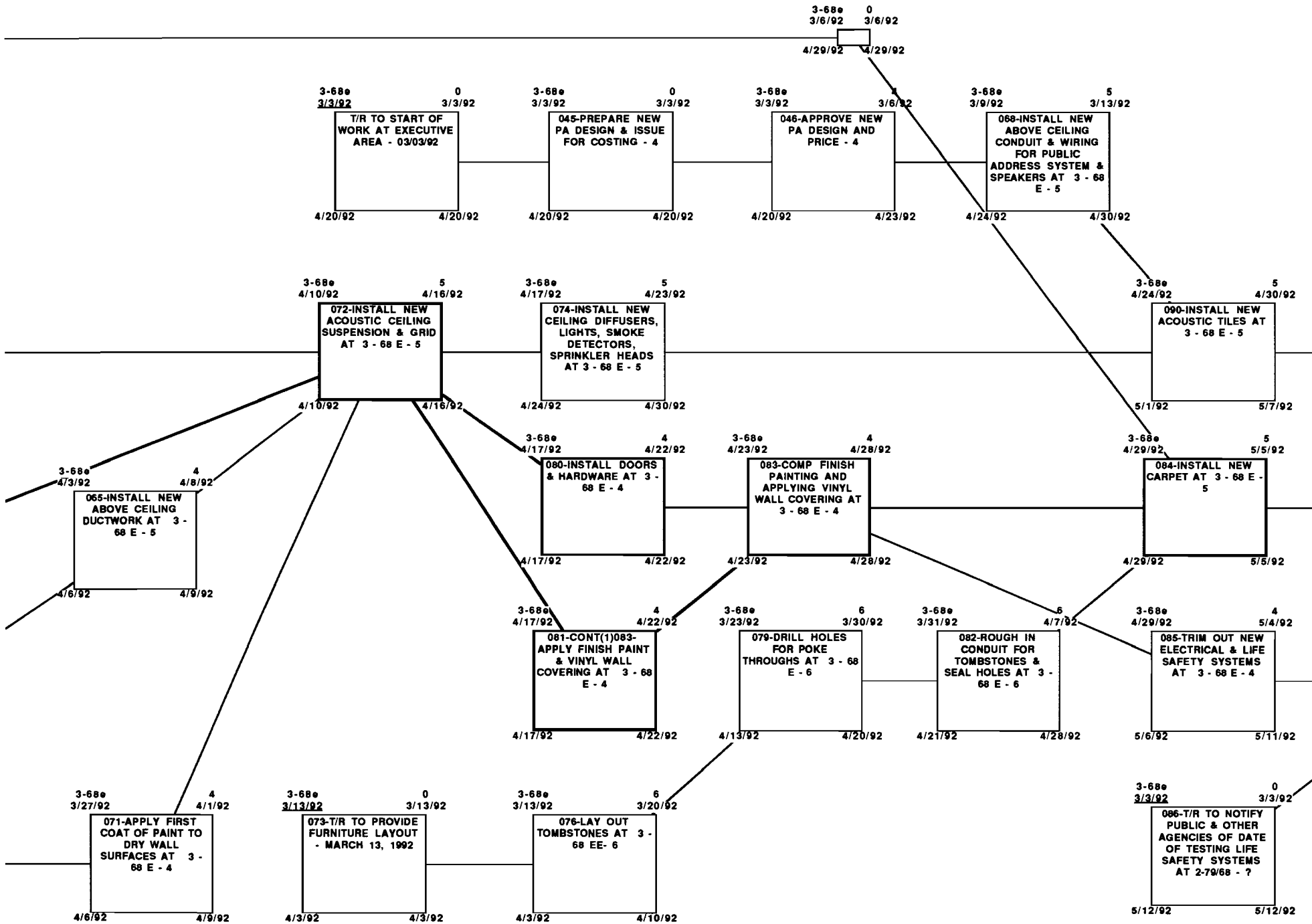

3rd Floor 68 executive
(3-68 e) Interior work

NETWORK MODEL FOR FIRST COLONY LIFE INSURANCE COMPANY OFFICE ADDITION Lynchburg, Virginia

Issue #1, 2 & 3 - not used
Issue #4 - March 3, 1992
I4sht#3-68 3e int work
disk 304

H. J. Construction Joint Venture
Lynchburg, Virginia 24506

Ralph J. Stephenson PE PE
Consulting Engineer
323 Hiawatha Drive
Mt. Pleasant, Michigan 48853
ph 517 772 2537

Sheet
3-68 e

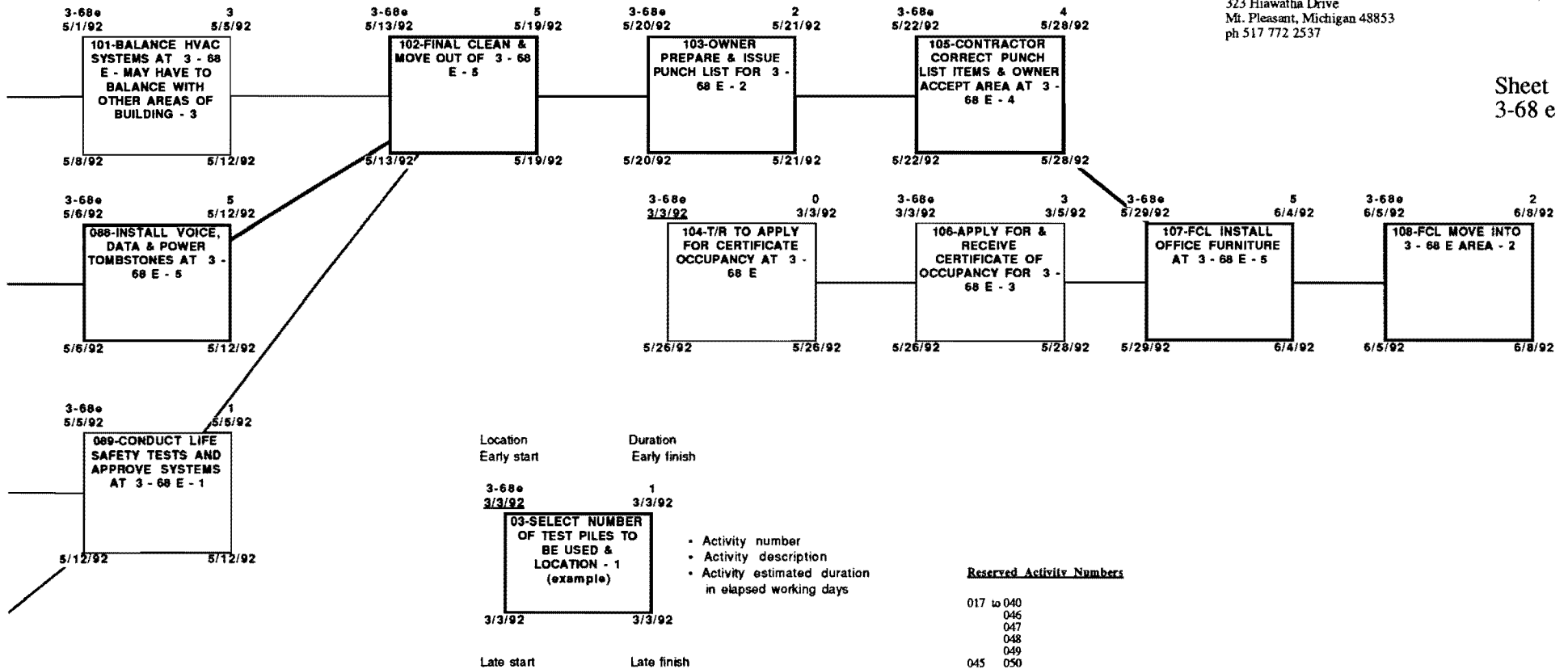

Location	Duration
Early start	Early finish
3-68e 3/3/92	1 3/3/92
3/3/92	3/3/92
Late start	Late finish

- Activity number
- Activity description
- Activity estimated duration in elapsed working days

Reserved Activity Numbers

- 017 to 040
- 046
- 047
- 048
- 049
- 045 to 050

ACTIVITY KEY

LAN 017
HAN 108

1st Floor 79 (1-79)
Interior work

2/91

2/91

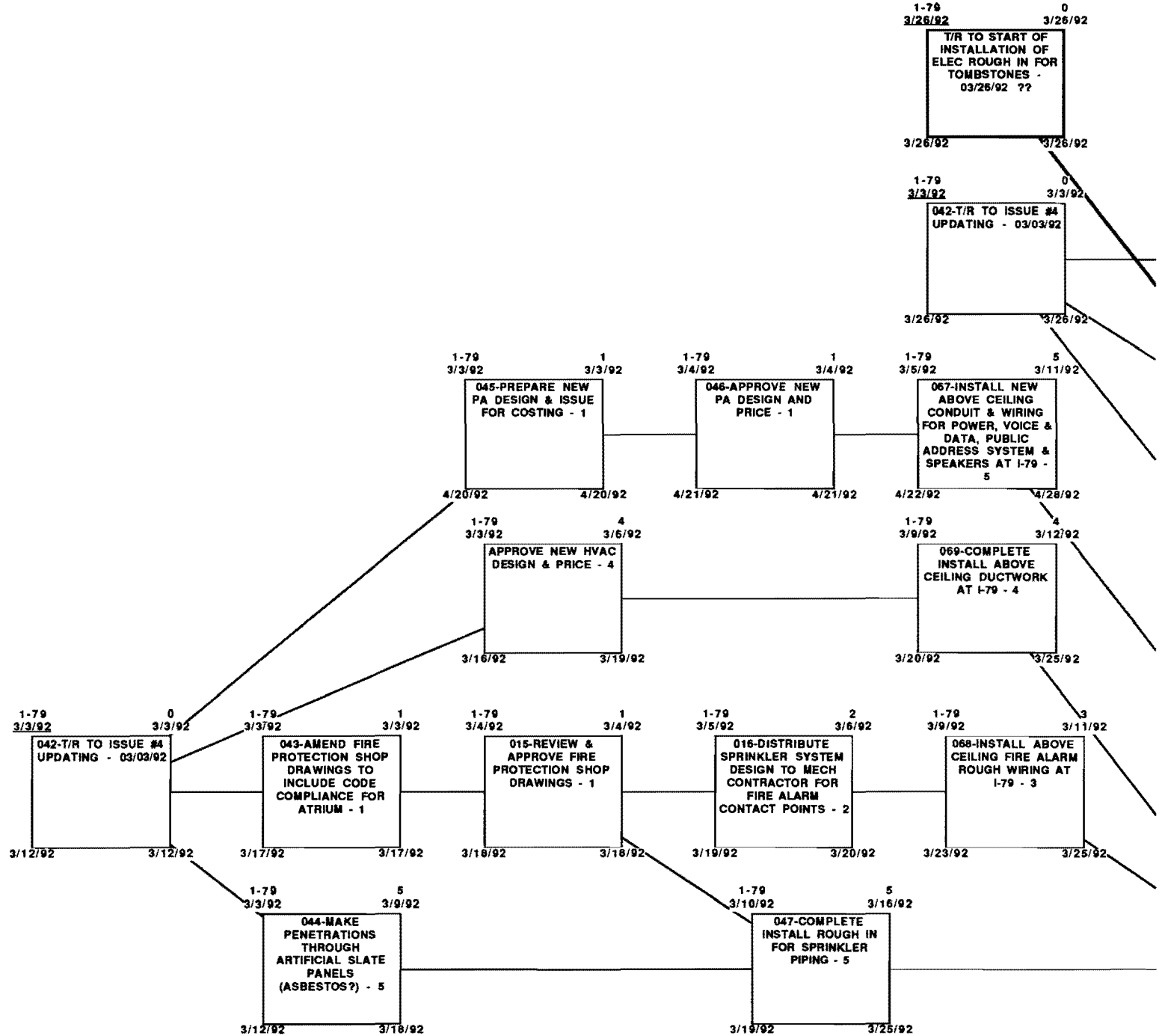

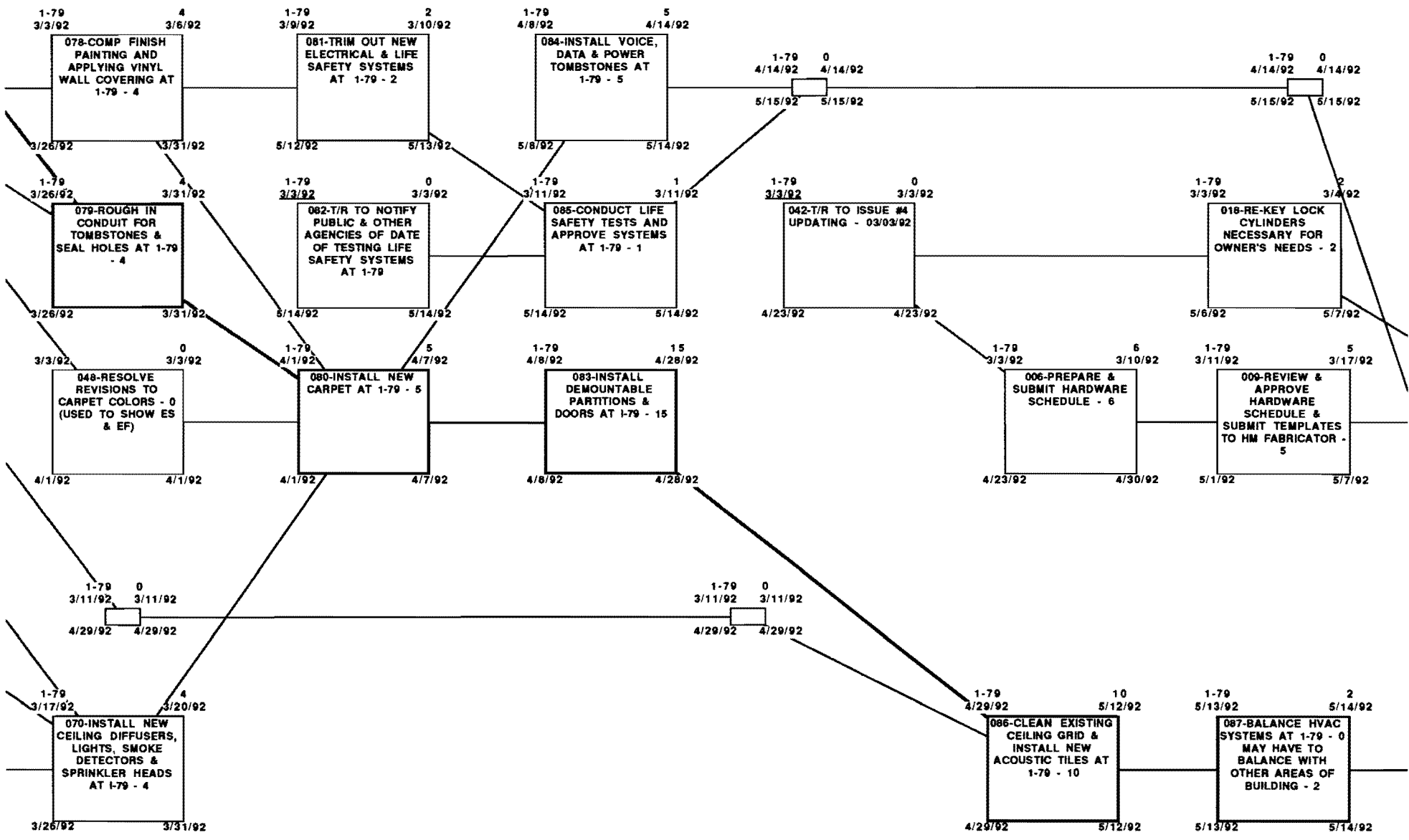

Reserved Activity Numbers

018 to 040
050

LAN 001
HAN 105

1st Floor 79 (1-79)
Interior work

NETWORK MODEL FOR FIRST COLONY LIFE INSURANCE COMPANY OFFICE ADDITION Lynchburg, Virginia

Issue #1 - October 9, 1991
Issue #2 - October 22, 1991
Issue #3 - December 3, 1991
Issue #3 - monitored 03/03/92
Issue #4 - March 3, 1992
i4sh#1-79
disk 304

H. J. Construction Joint Venture
Lynchburg, Virginia 24506

Ralph J. Stephenson PE PE
Consulting Engineer
323 Hiawatha Drive
Mt. Pleasant, Michigan 48853
ph 517 772 2537

Sheet
#1-79

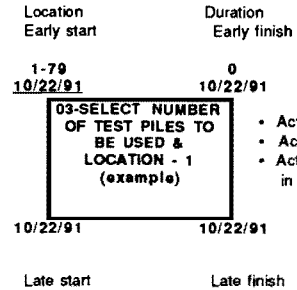
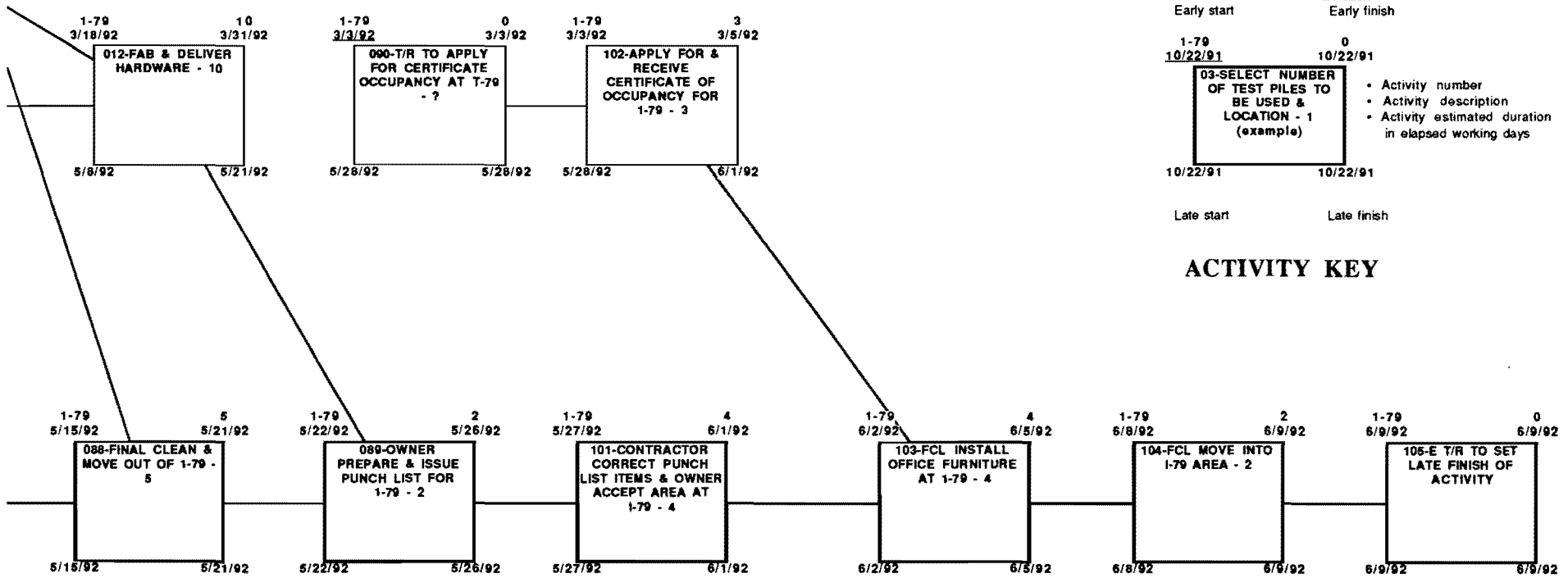

ACTIVITY KEY

91:37

Ralph J. Stephenson PE PC
Consulting Engineer

FCL2

October 25, 1991

Mr. Steve Greene, Assistant Vice President
First Colony Life Insurance Company
PO Box 1280
700 Main Street
Lynchburg, VA 24505

Re: *Issue #2 network models of existing building renovation - First Colony Office Building, Lynchburg, Virginia - rjs project 91:37*

Dear Steve:

Enclosed are seven network models of the various geographic areas to be remodeled in the existing building renovation. All are labeled issue #2, dated October 22, 1991 and were updated from the issue #1 networks prepared in our October 7th and 8th, 1991 sessions.

Included are the following:

- *Sheet LL* - issue 2, dated October 22, 1991 - move in date - pm January 7, 1992
- *Sheet 3 - 79/79 ne* - issue 2, dated October 22, 1991 - move in date - pm March 30, 1992
- *Sheet T - 79* - issue 2, dated October 22, 1991 - move in date - pm April 8, 1992
- *Sheet 1 - 79* - issue 2, dated October 22, 1991 - move in date - pm April 15, 1992
- *Sheet 2 - 79/68* - issue 2, dated October 22, 1991 - move in date - pm May 7, 1992
- *Sheet 1 - 68* - issue 2, dated October 22, 1991 - move in date - pm October 27, 1992
- *Sheet T - 79* - issue 2, dated October 22, 1991 - move in date - pm April 21, 1993

These networks have been left unassembled as we discussed on the phone the other day. However I have stapled a small key plan to each set of diagrams and the paste up process should be relatively simple.

Once you have all had a chance to go through the diagrams in detail I'm certain there will be some revisions and additions. The total project end date seems to be considerably later than I should think it would be on a project of this type. However I have taken the material sent to me and converted it

Ralph J. Stephenson PE PC
Consulting Engineer

October 25, 1991

as well as possible to what is considered to be the desired sequence of work. It would be well to carefully review the dates, logic and durations with your construction team before officially issuing the diagrams.

Notice the summary network model is not included. After trying to accommodate some of the partial moves and intermediate dates in the summary plan, I decided to wait until we meet again to complete this network model to insure accuracy.

If you do need the summary sooner I can construct it from the detailed diagrams already prepared. However I would prefer to complete it with you, Phil and Don.

If there are any questions please call or write.

Enclosures: Network models

Sincerely yours,

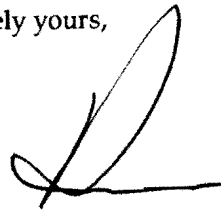
A handwritten signature in black ink, appearing to be 'R. Stephenson', written in a cursive style.

Ralph J. Stephenson, P. E.

21

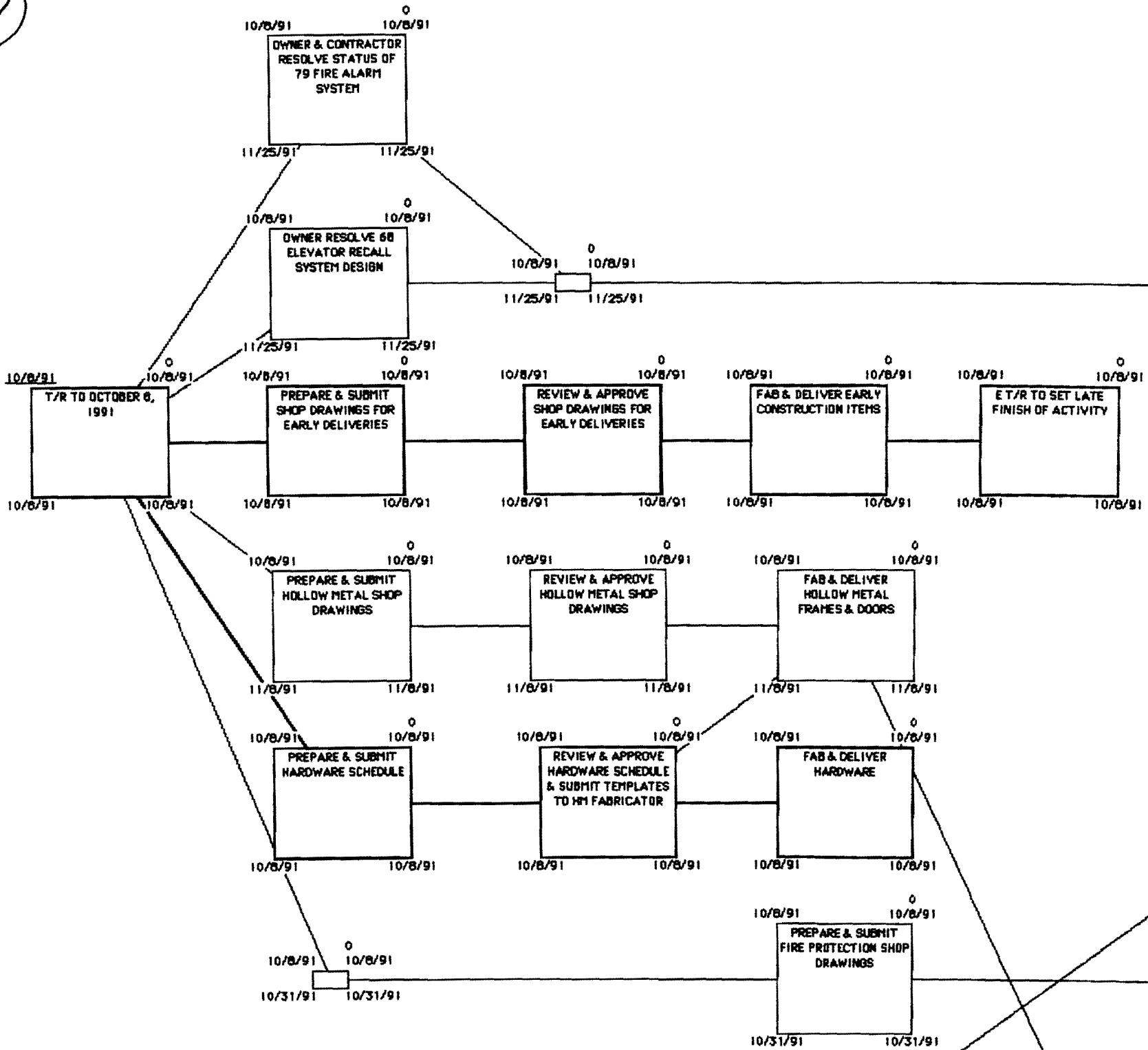

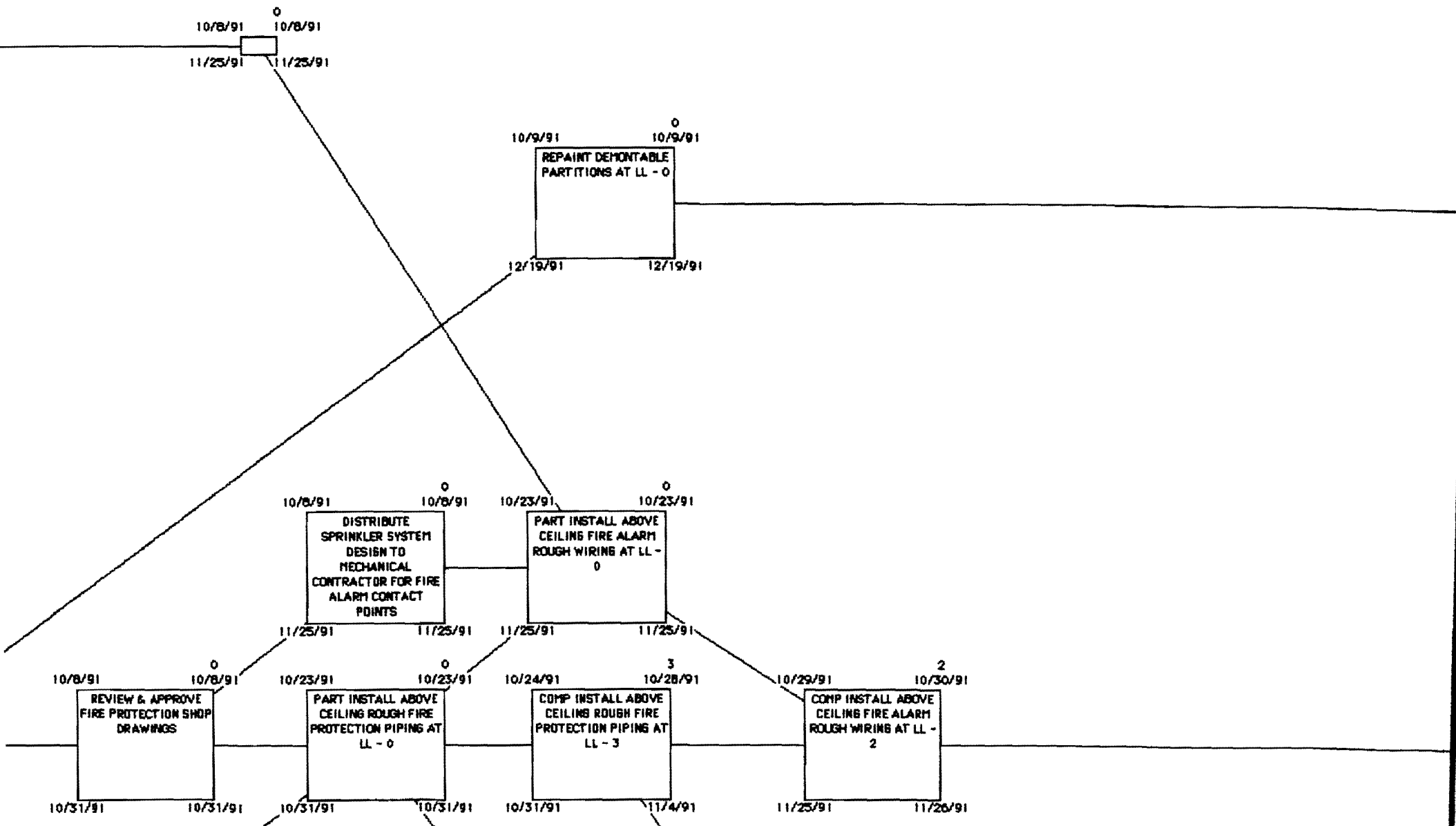

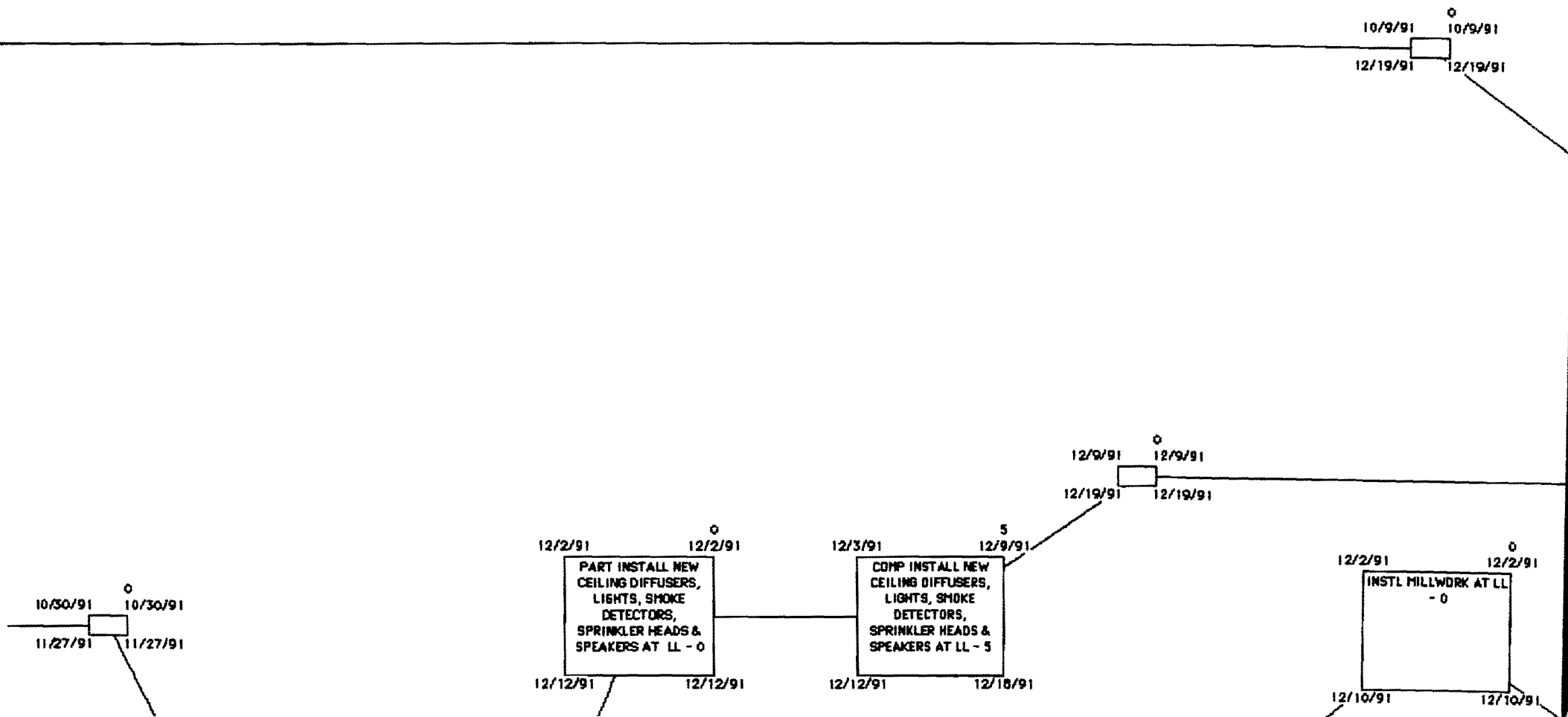

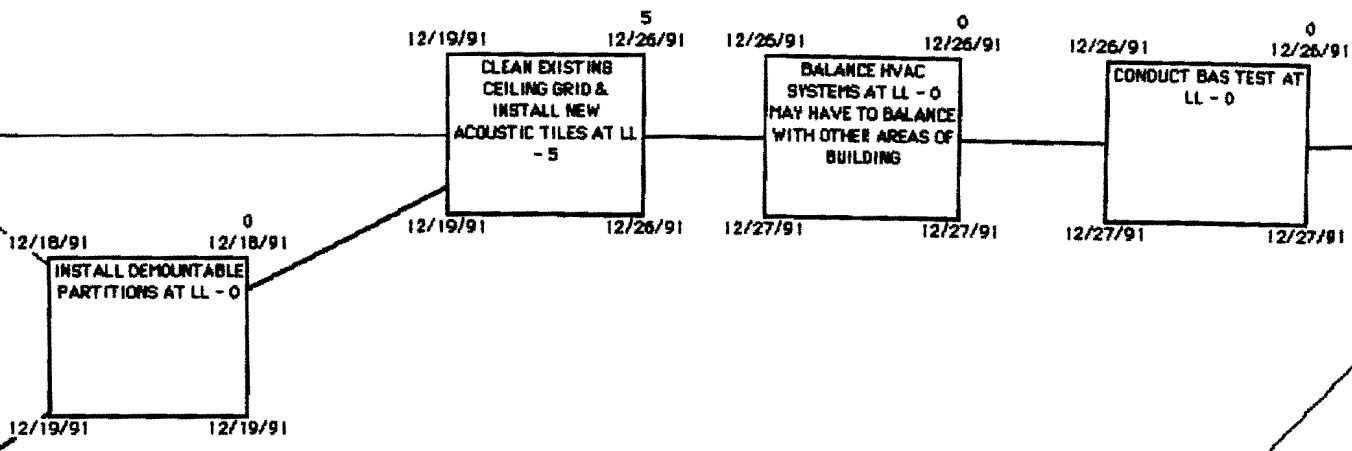
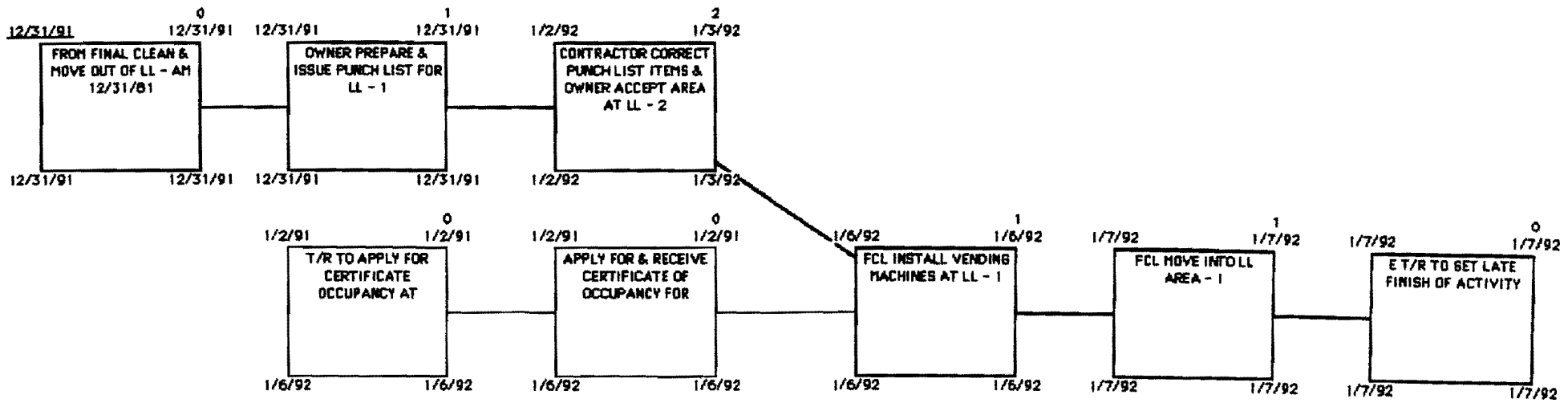

2

12/27/91 12/30/91

FINAL CLEAN & MOVE
OUT OF LL - 2

12/27/91 12/30/91



61

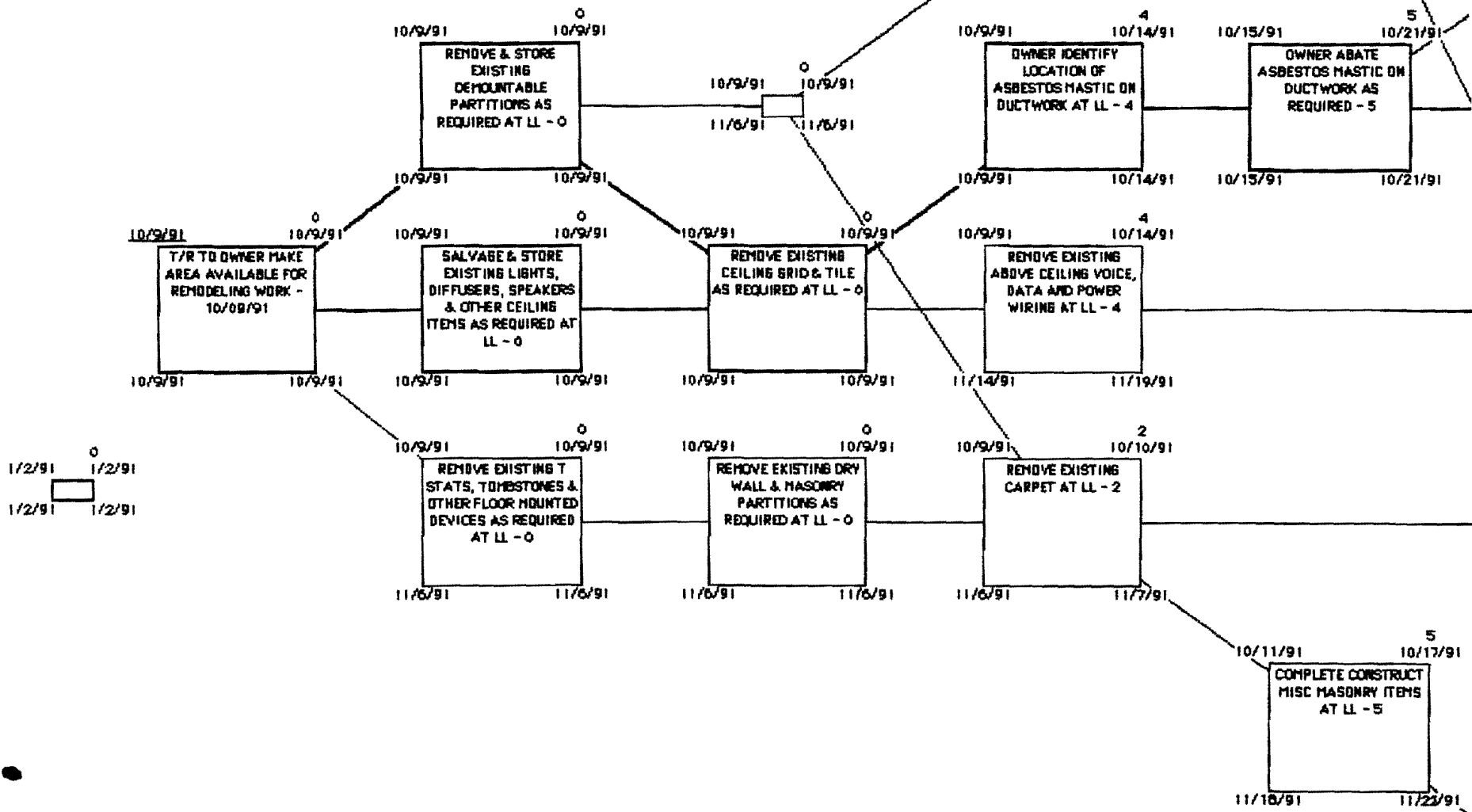

10/22/91 2 10/23/91
 REMOVE ABOVE CEILING DUCTWORK AS REQUIRED AT LL - 2

10/23/91 10/26/91

10/22/91 5 10/28/91
 CLEAN EXISTING ABOVE CEILING DUCTWORK WITH VACUUM CLEANING AT LL - 5

10/22/91 10/26/91

10/29/91 5 11/4/91
 INSTALL NEW ABOVE CEILING ELECTRICAL CABLE TRAY AT LL - 5

10/29/91 11/4/91

11/4/91 0 11/4/91
 PART INSTALL NEW ABOVE CEILING DUCTWORK AT LL - 0

11/5/91 11/5/91

11/5/91 3 11/7/91
 COMPLETE INSTALL ABOVE CEILING DUCTWORK AT LL - 3

11/5/91 11/7/91

11/4/91 0 11/4/91
 PART INSTALL NEW ABOVE CEILING CONDUIT & WIRING FOR POWER, VOICE & DATA AND PUBLIC ADDRESS SYSTEM AT LL - 0

11/20/91 11/20/91

11/5/91 5 11/11/91
 COMP INSTALL NEW ABOVE CEILING CONDUIT & WIRING FOR POWER, VOICE & DATA AND PUBLIC ADDRESS SYSTEM AT - 5

11/20/91 11/26/91

10/10/91 0 10/10/91
 PART INSTALL METAL STUDS & IN WALL WORK FOR WALLS EXTENDING FROM STRUCT TO STRUCT AT LL - 0

11/8/91 11/8/91

IN WALL ITEMS INCLUDE

- BLOCKING
- CONDUIT
- FRAMES
- PIPING

11/8/91 6 11/15/91
 COMP INSTALL METAL STUDS & IN WALL WORK FOR WALLS EXTENDING FROM STRUCT TO STRUCT AT LL - 6

11/8/91 11/15/91

10/10/91 0 10/10/91
 PART HANG & FINISH NEW DRY WALL AT STRUCT TO STRUCT PARTITIONS AT LL - 0

11/18/91 11/18/91

11/18/91 5 11/22/91
 COMP HANG & FINISH NEW DRY WALL AT STRUCT TO STRUCT PARTITIONS - 5

11/18/91 11/22/91

11/17/91 0 10/17/91
 11/25/91 11/25/91

10/17/91 0 10/17/91
 11/25/91 11/25/91

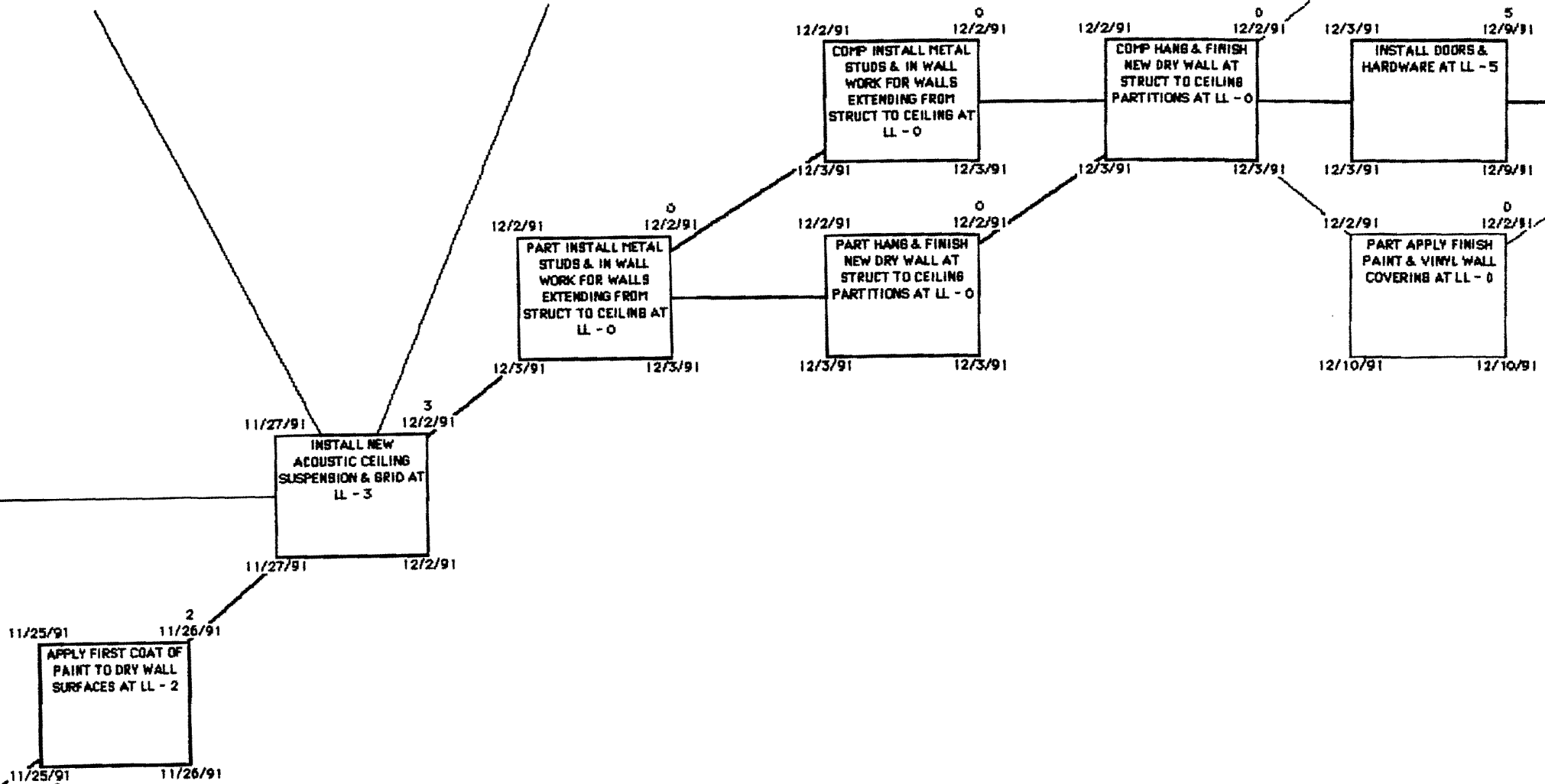

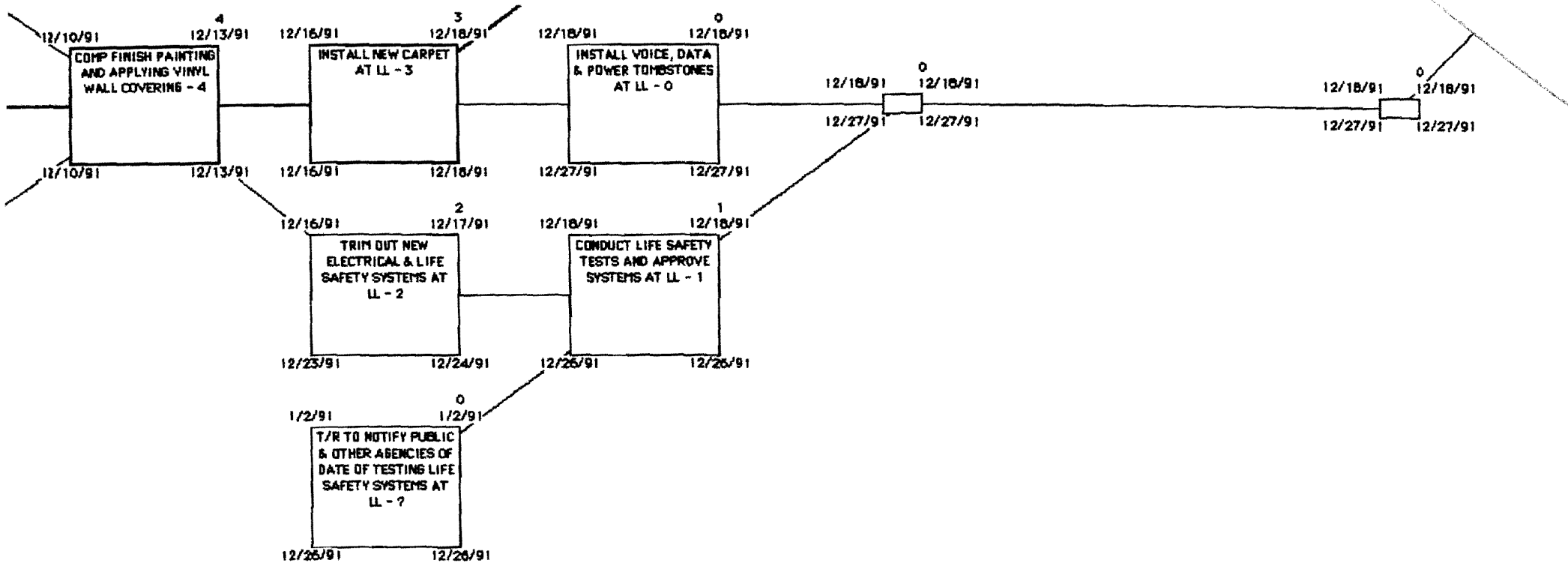

Interior Work for Lower Level

NETWORK MODEL FOR FIRST COLONY LIFE INSURANCE COMPANY OFFICE ADDITION Lynchburg, Virginia

**H. J. Construction Joint Venture
Lynchburg, Virginia 24506**

Ralph J. Stephenson PE PE
Consulting Engineer
323 Hiawatha Drive
Mt. Pleasant, Michigan 48853
ph 517 772 2537

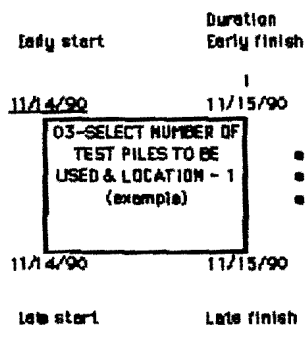

- Activity number
- Activity description
- Activity estimated duration in elapsed working days

Reserved Activity Numbers

041	046
042	047
043	048
044	049
045	050

Issue #1 - October 9, 1991
 1st=LL int work
 disk 203

ACTIVITY

21
7-79

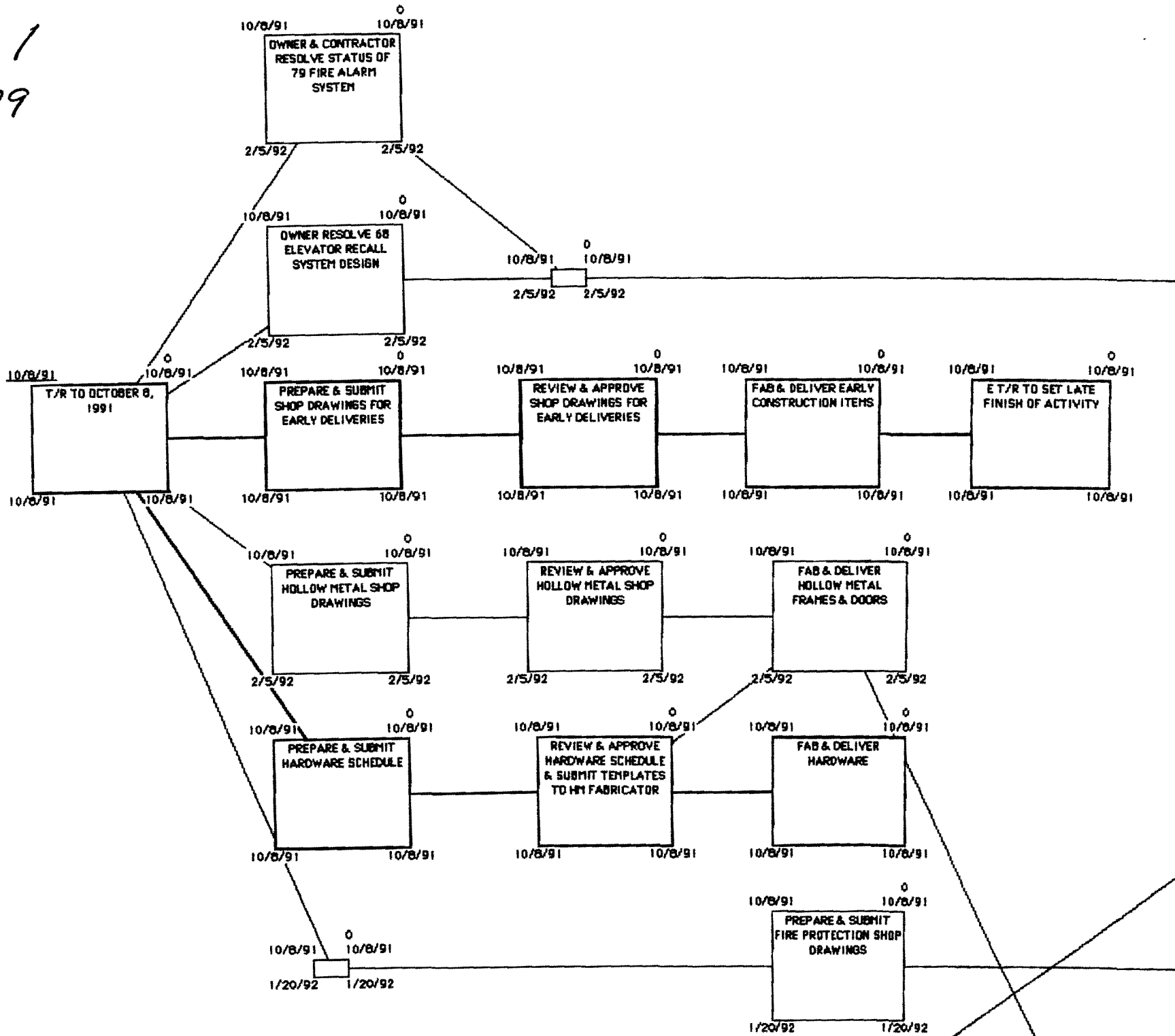

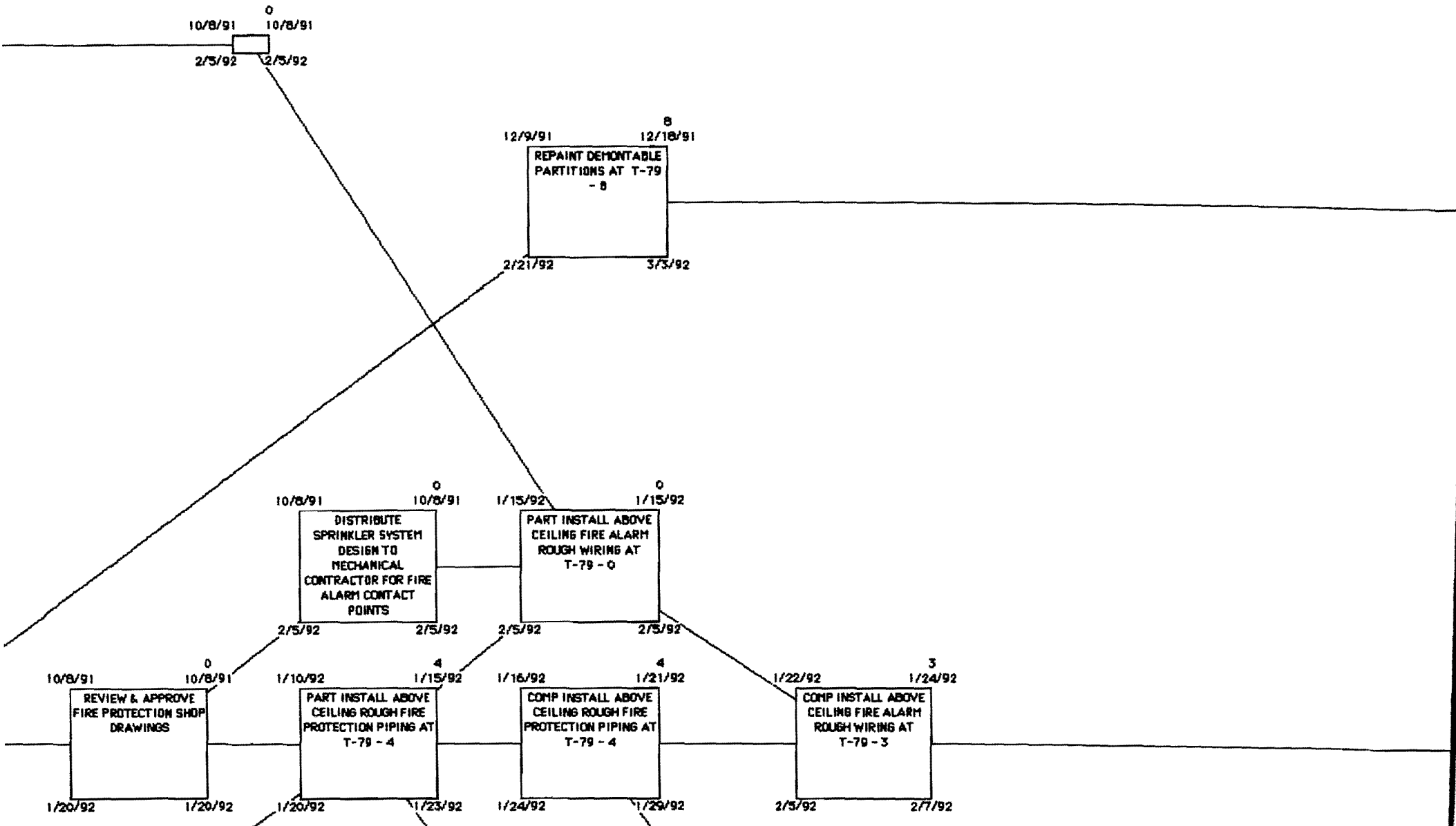

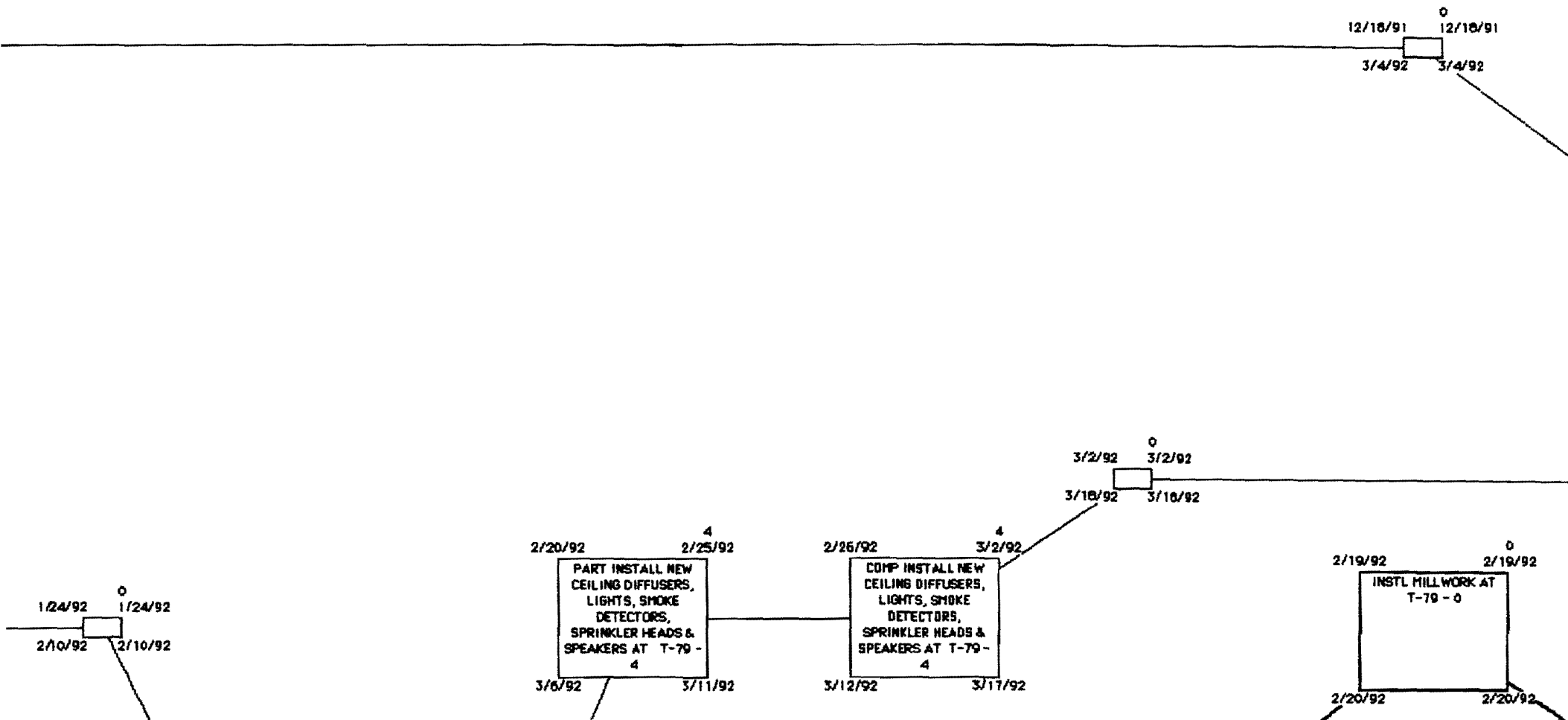

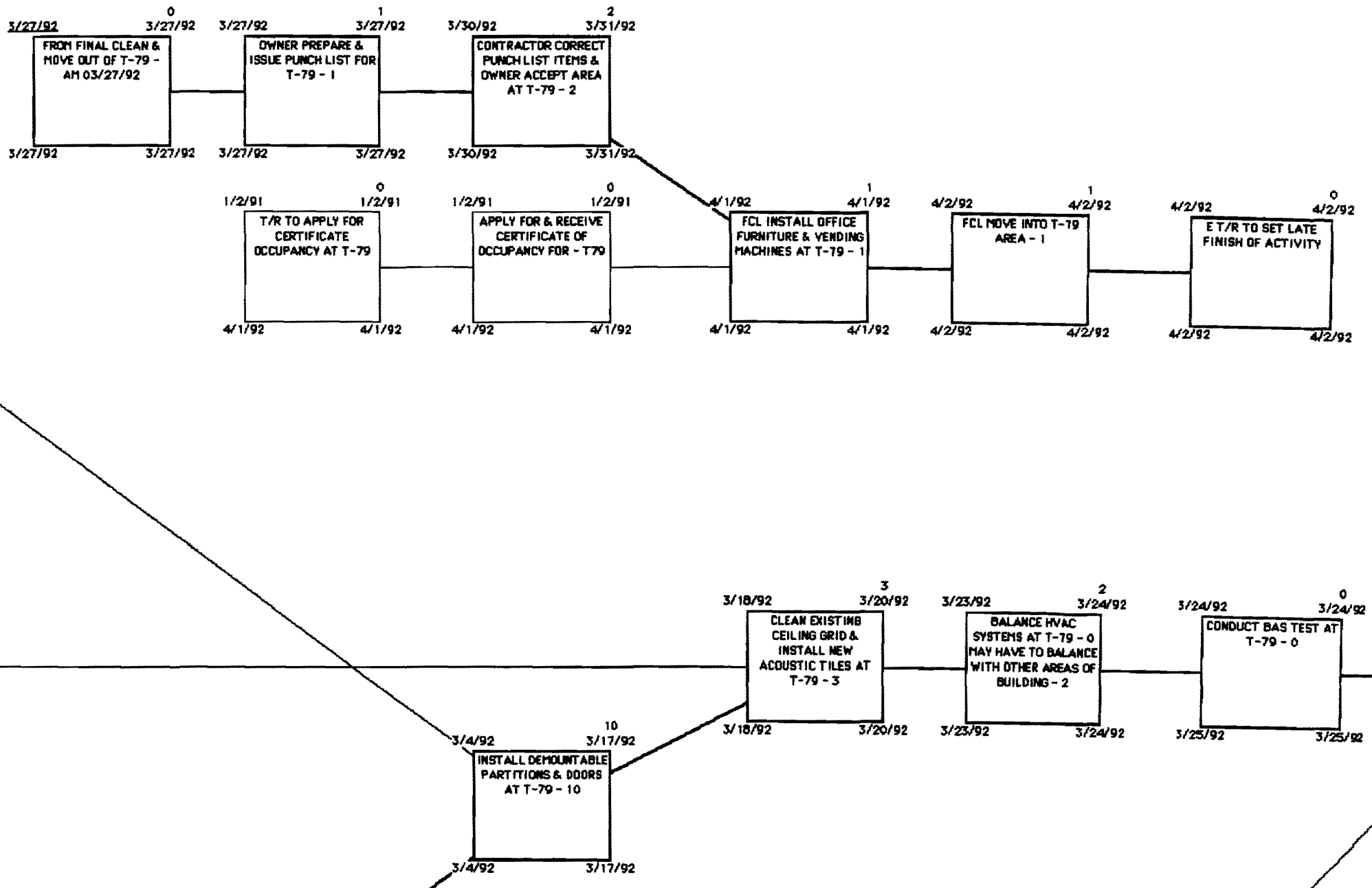

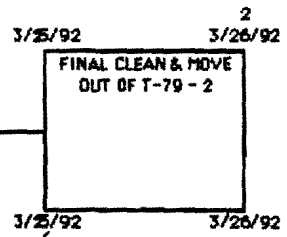

C1
T-79

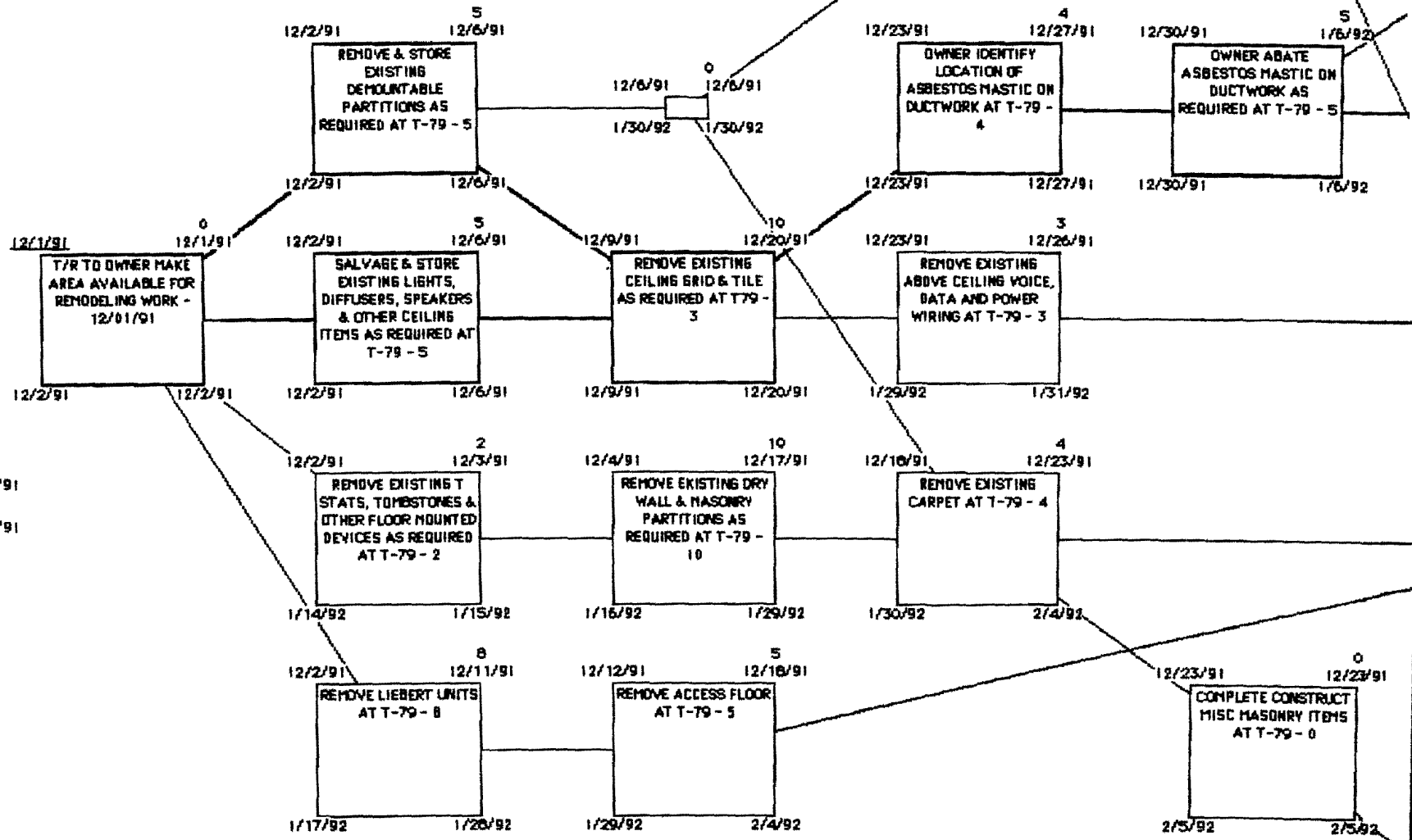
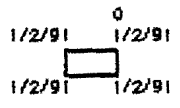

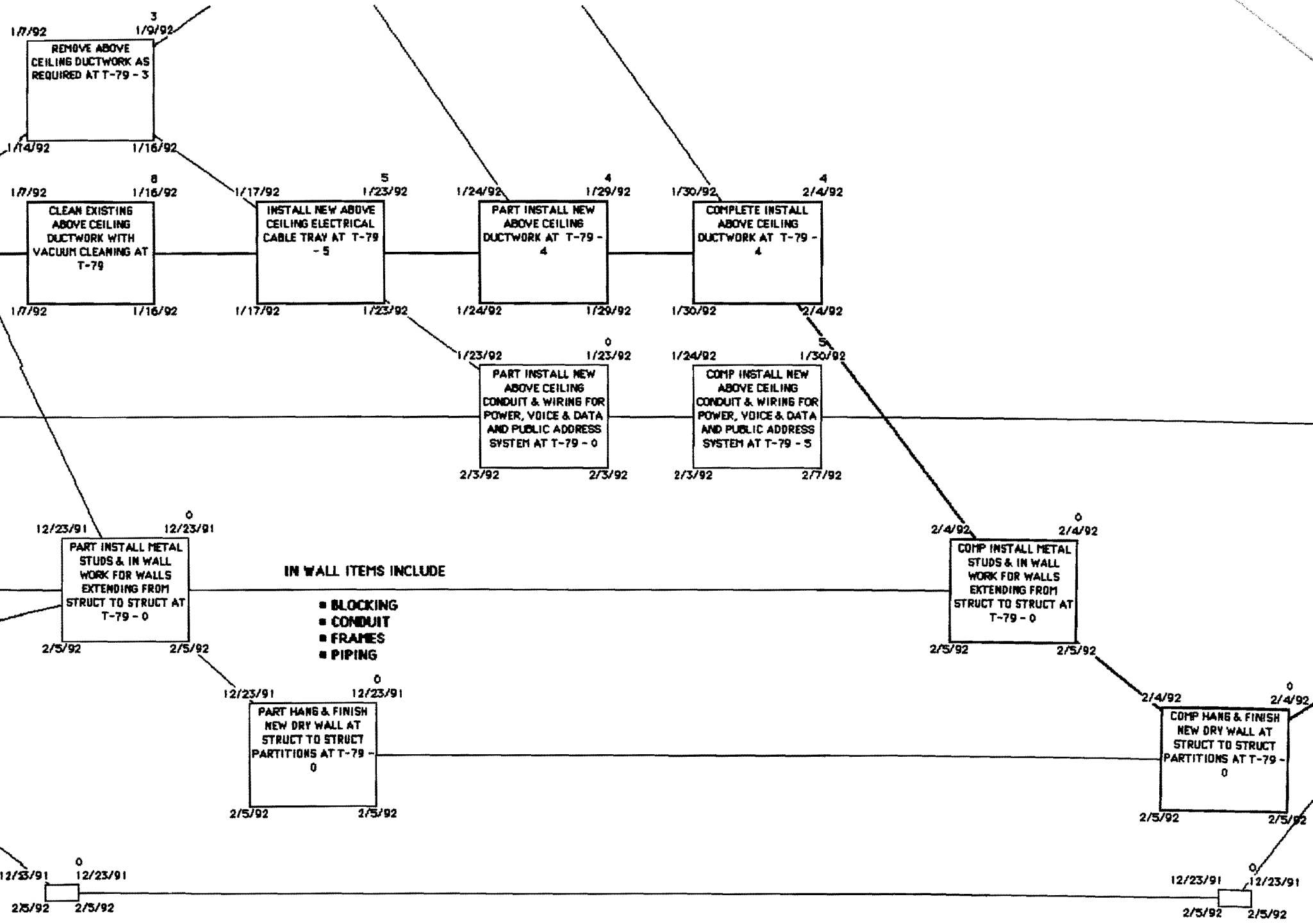

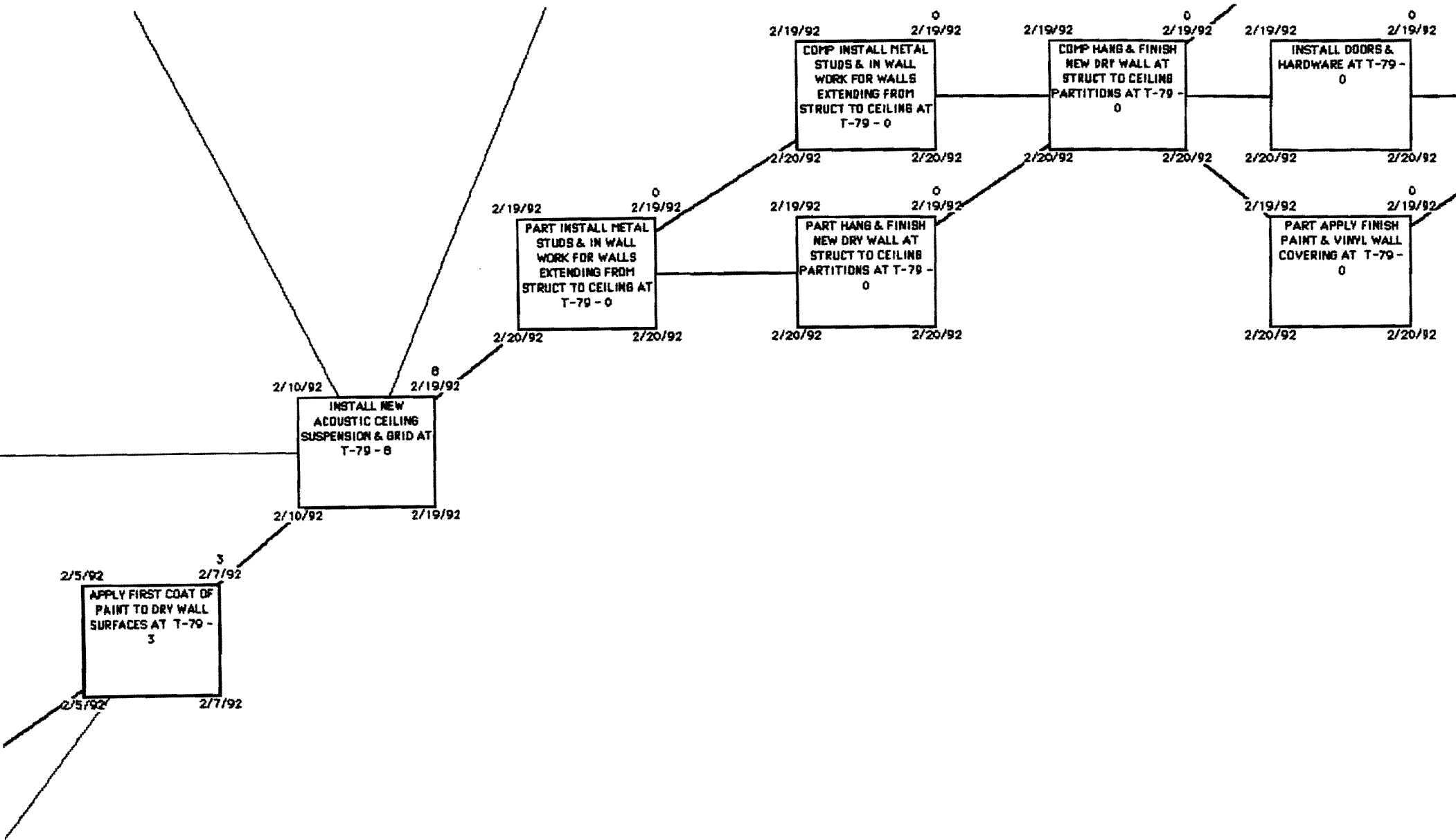

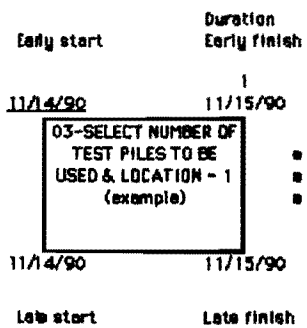
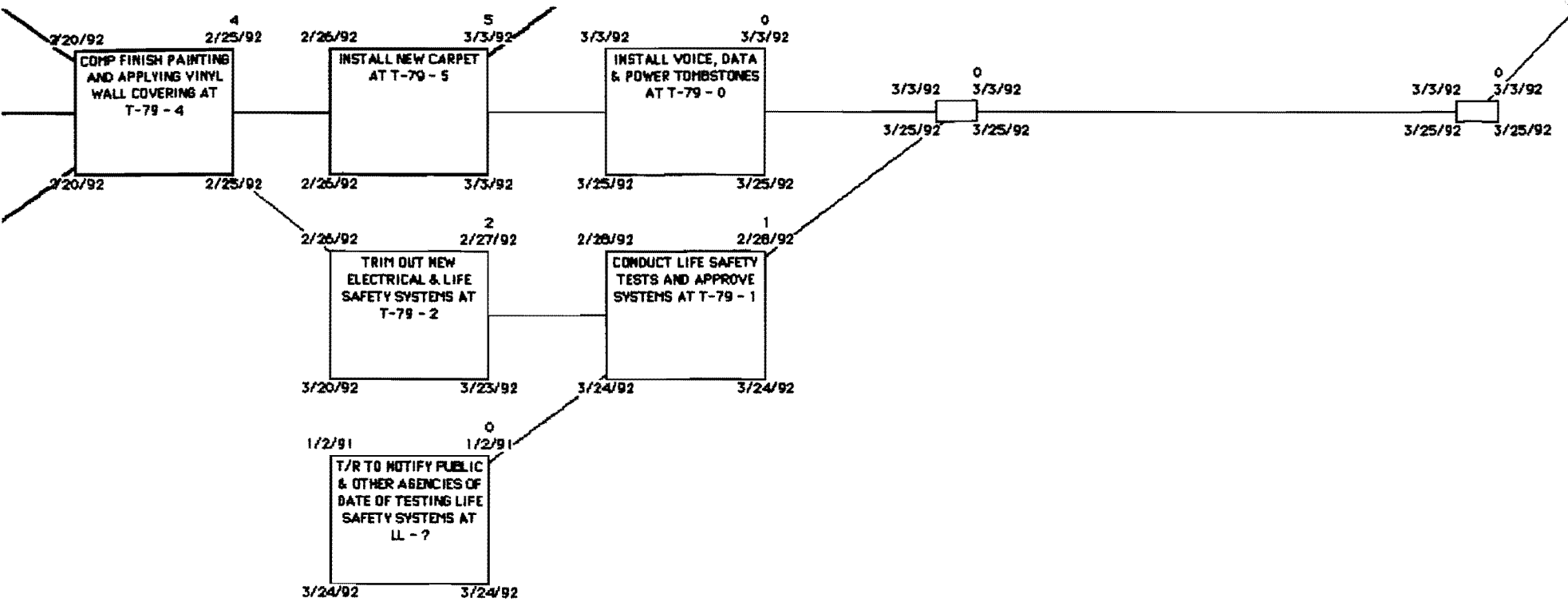

- Activity number
- Activity description
- Activity estimated duration in elapsed working days

Reserved Activity Numbers

041	046
042	047
043	048
044	049
045	050

ACTIVITY

Interior work for terrace 79 area - T-79

NETWORK MODEL FOR FIRST COLONY LIFE INSURANCE COMPANY OFFICE ADDITION Lynchburg, Virginia

H. J. Construction Joint Venture
Lynchburg, Virginia 24506

Ralph J. Stephenson PE PE
Consulting Engineer
323 Hiawatha Drive
Mt. Pleasant, Michigan 48853
ph 517 772 2537

Issue #1 - October 9, 1991
11st-T-79-1 int work
disk 263

01

3-79/68 XJE

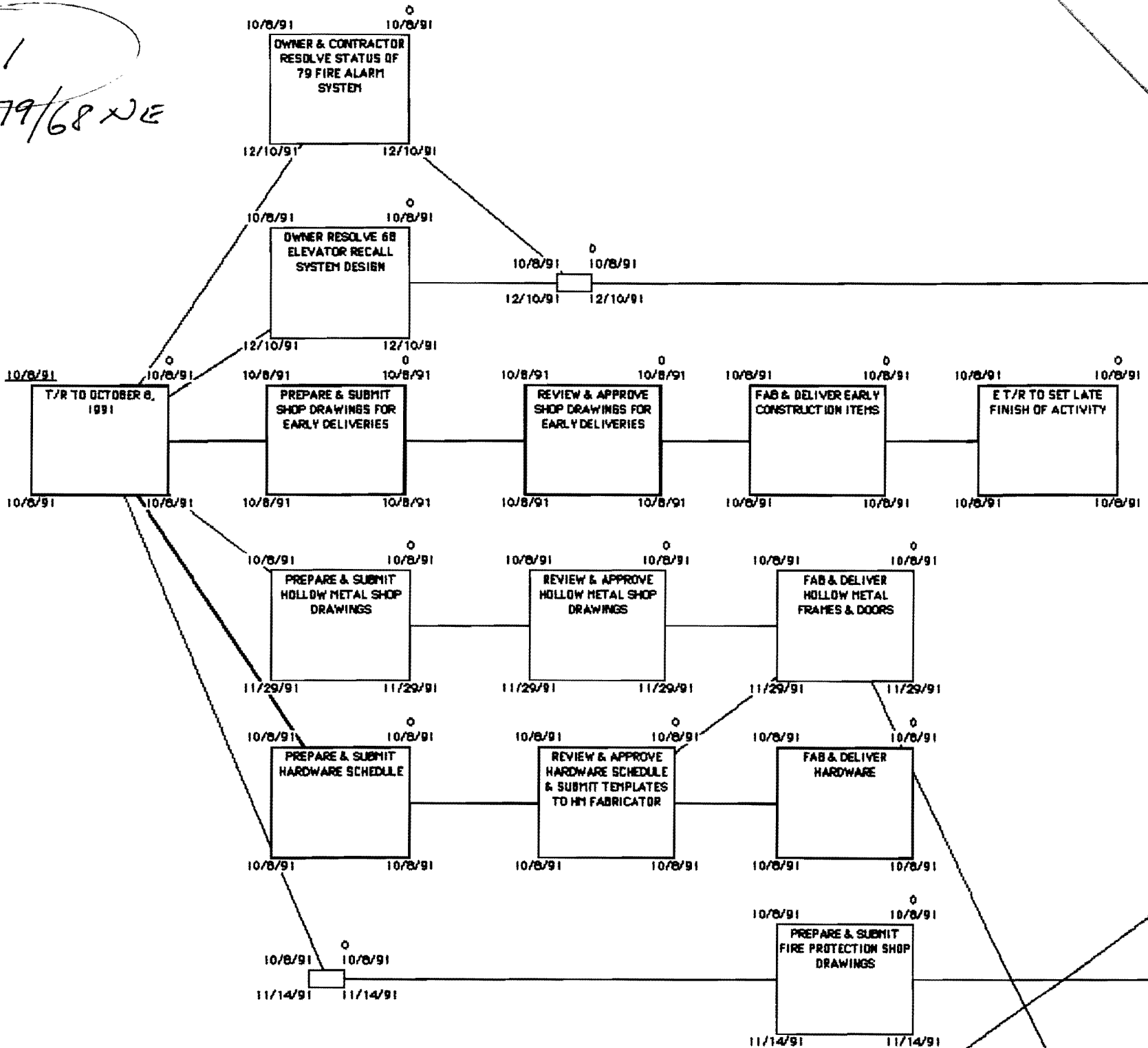

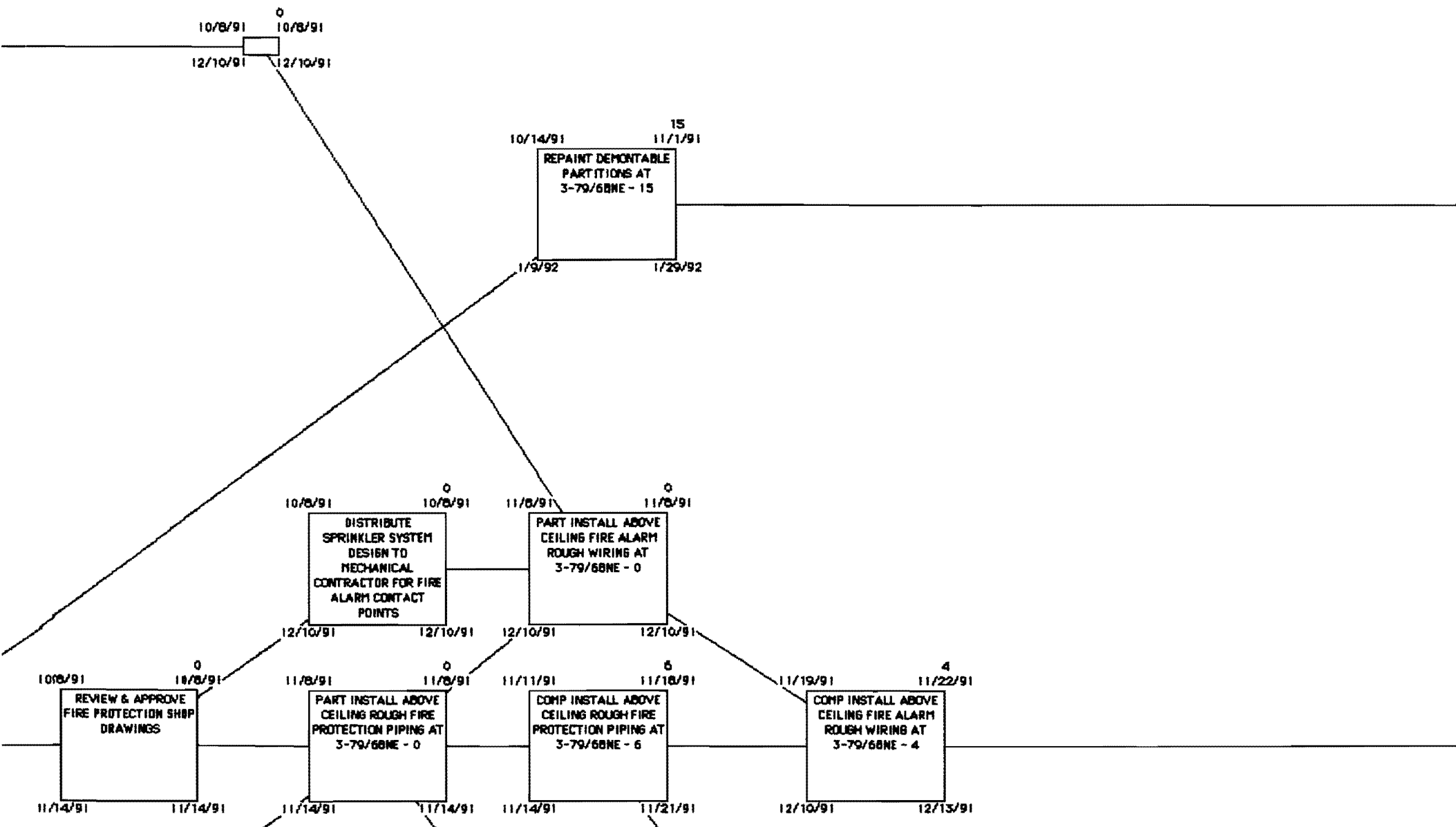

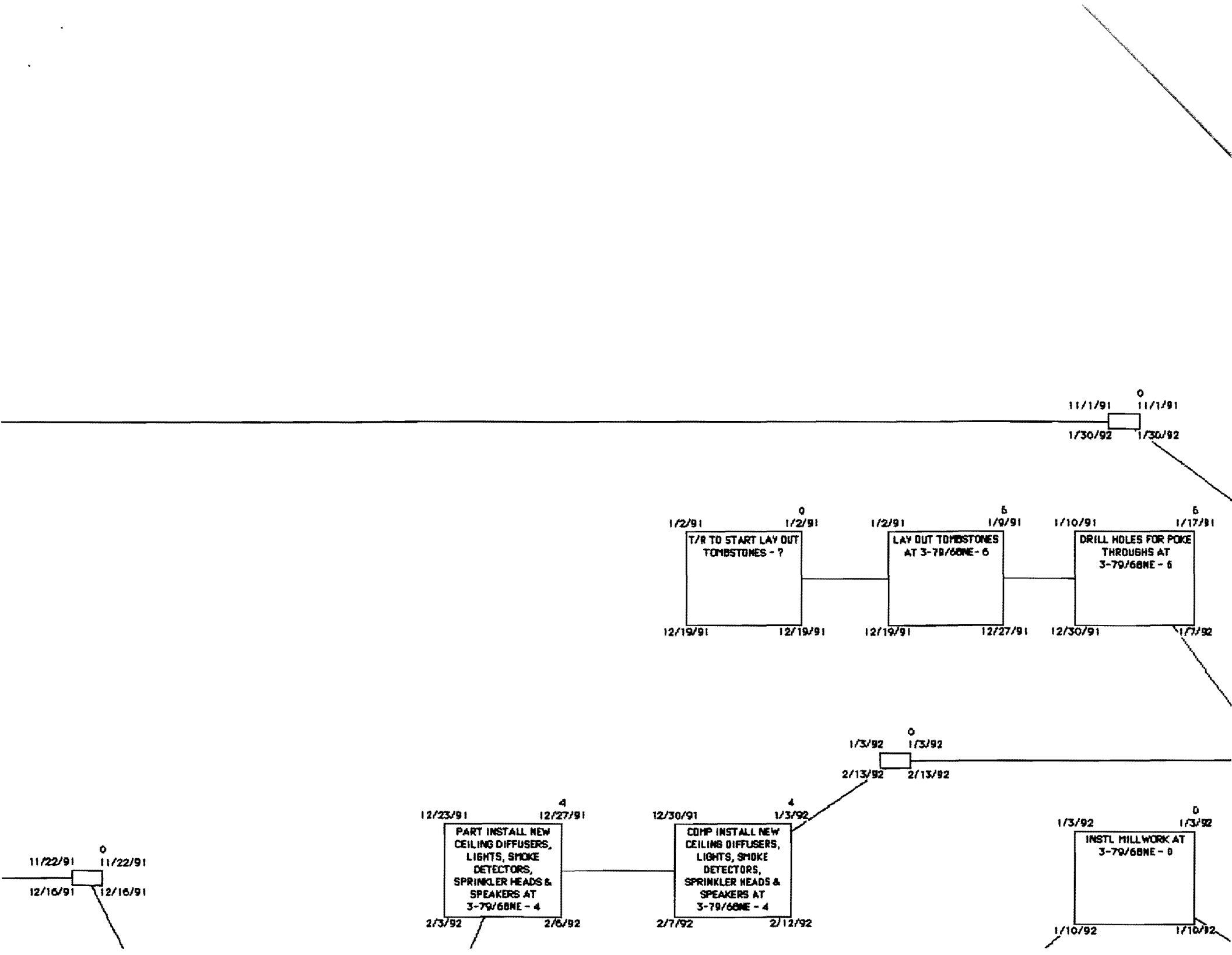

11/1/91 0
11/1/91
1/30/92 1/30/92

1/2/91 0 1/2/91 1/2/91 1/2/91 6 1/9/91 1/10/91 6 1/17/91
 T/R TO START LAY OUT TOMBSTONES - ? LAY OUT TOMBSTONES AT 3-78/68NE-6 DRILL HOLES FOR POKE THROUGHES AT 3-79/68NE-6
 12/19/91 12/19/91 12/19/91 12/27/91 12/30/91 1/17/92

1/3/92 0 1/3/92
 2/13/92 2/13/92

12/23/91 4 12/27/91 12/30/91 4 1/3/92
 PART INSTALL NEW CEILING DIFFUSERS, LIGHTS, SMOKE DETECTORS, SPRINKLER HEADS & SPEAKERS AT 3-79/68NE-4 COMP INSTALL NEW CEILING DIFFUSERS, LIGHTS, SMOKE DETECTORS, SPRINKLER HEADS & SPEAKERS AT 3-79/68NE-4
 2/3/92 2/6/92 2/7/92 2/12/92

1/3/92 0 1/3/92
 INSTL MILLWORK AT 3-79/68NE-0
 1/10/92 1/10/92

11/22/91 0 11/22/91
 12/16/91 12/16/91

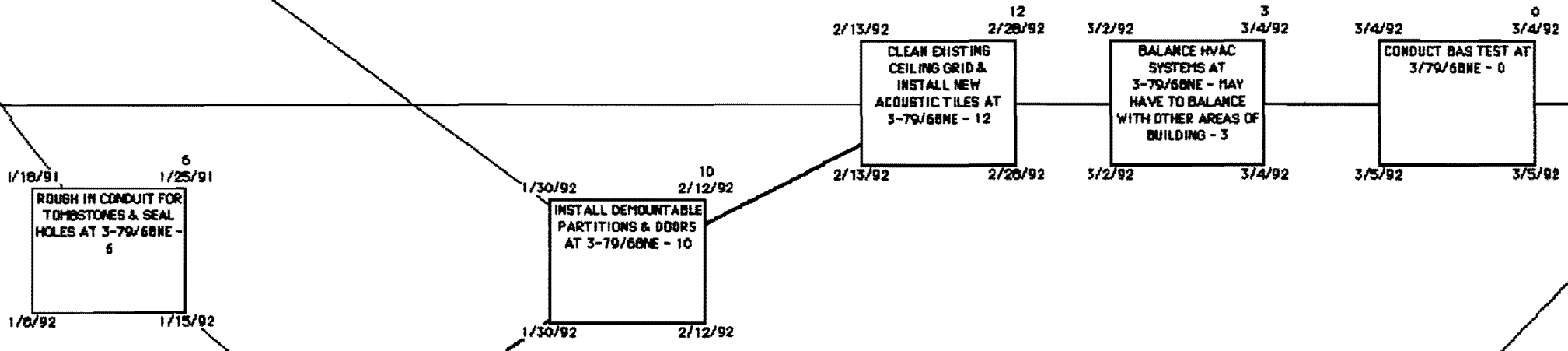
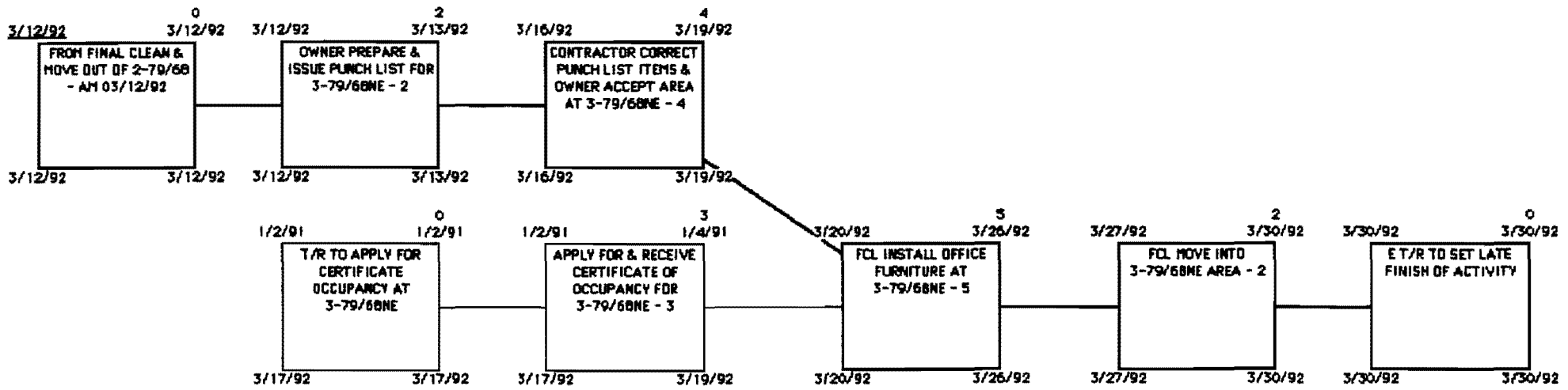

3/5/92 5 3/11/92
FINAL CLEAN & MOVE
OUT OF 3-79/68ME - 5
3/5/92 3/11/92

(i1)
3-79/68 NE

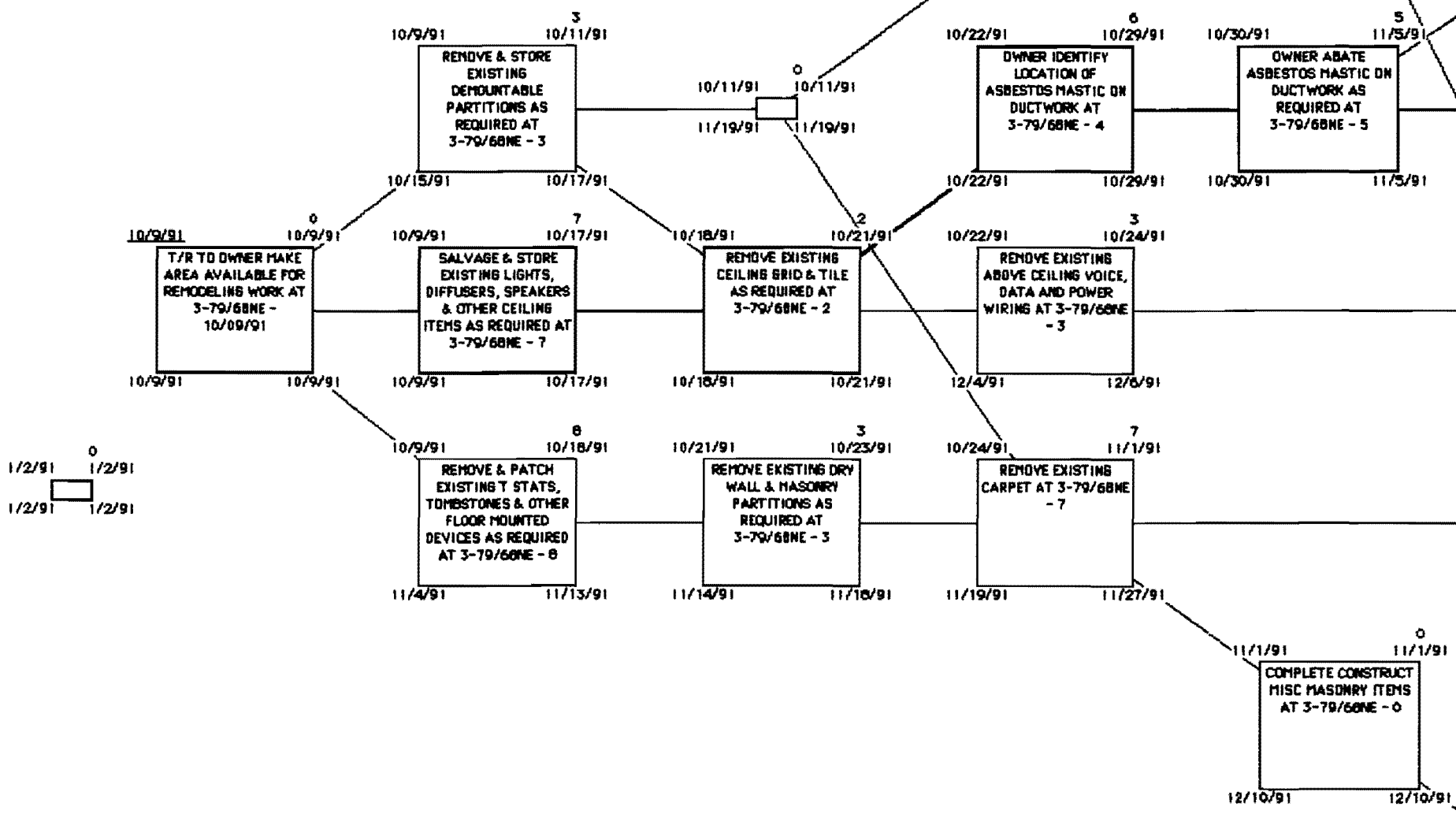

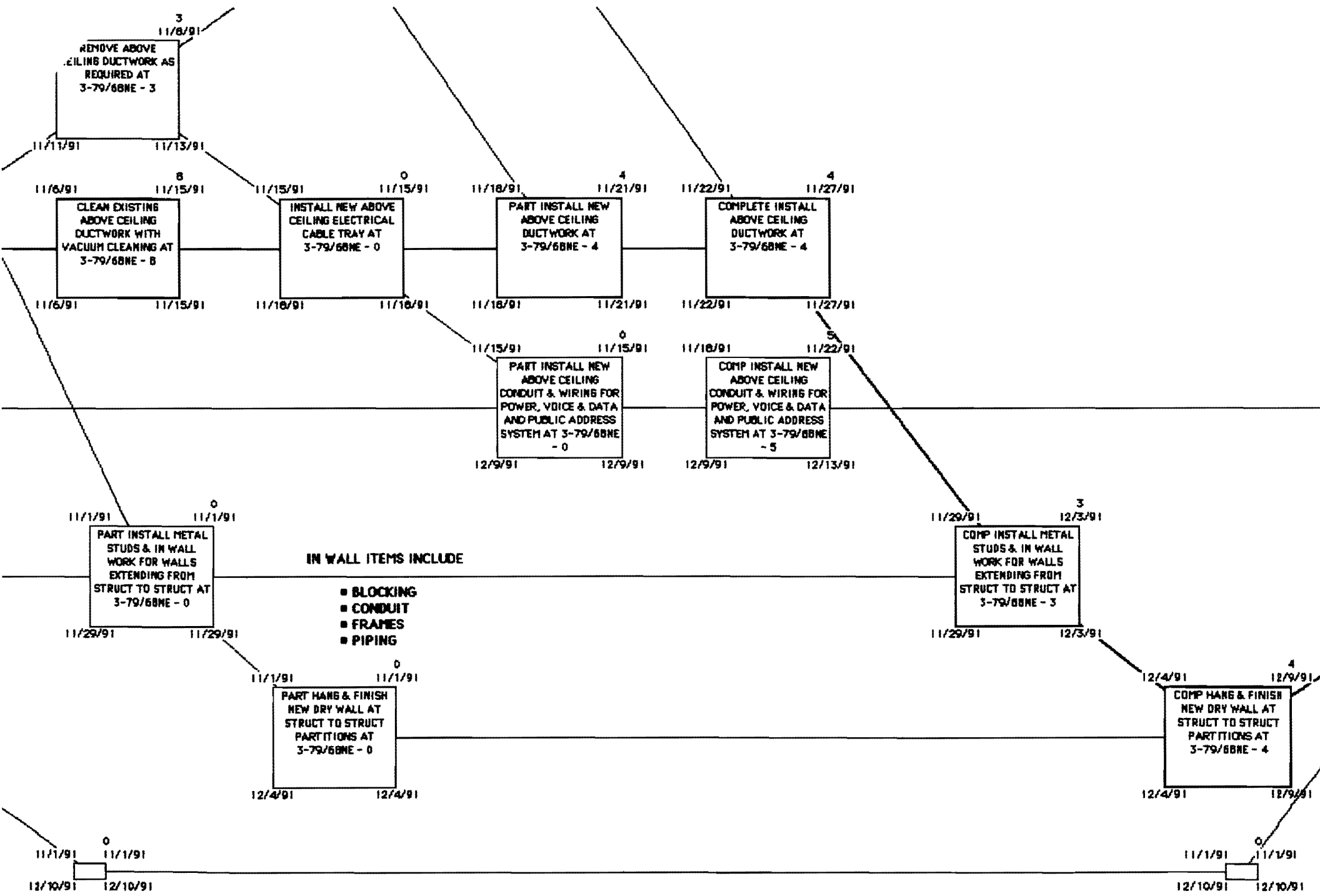

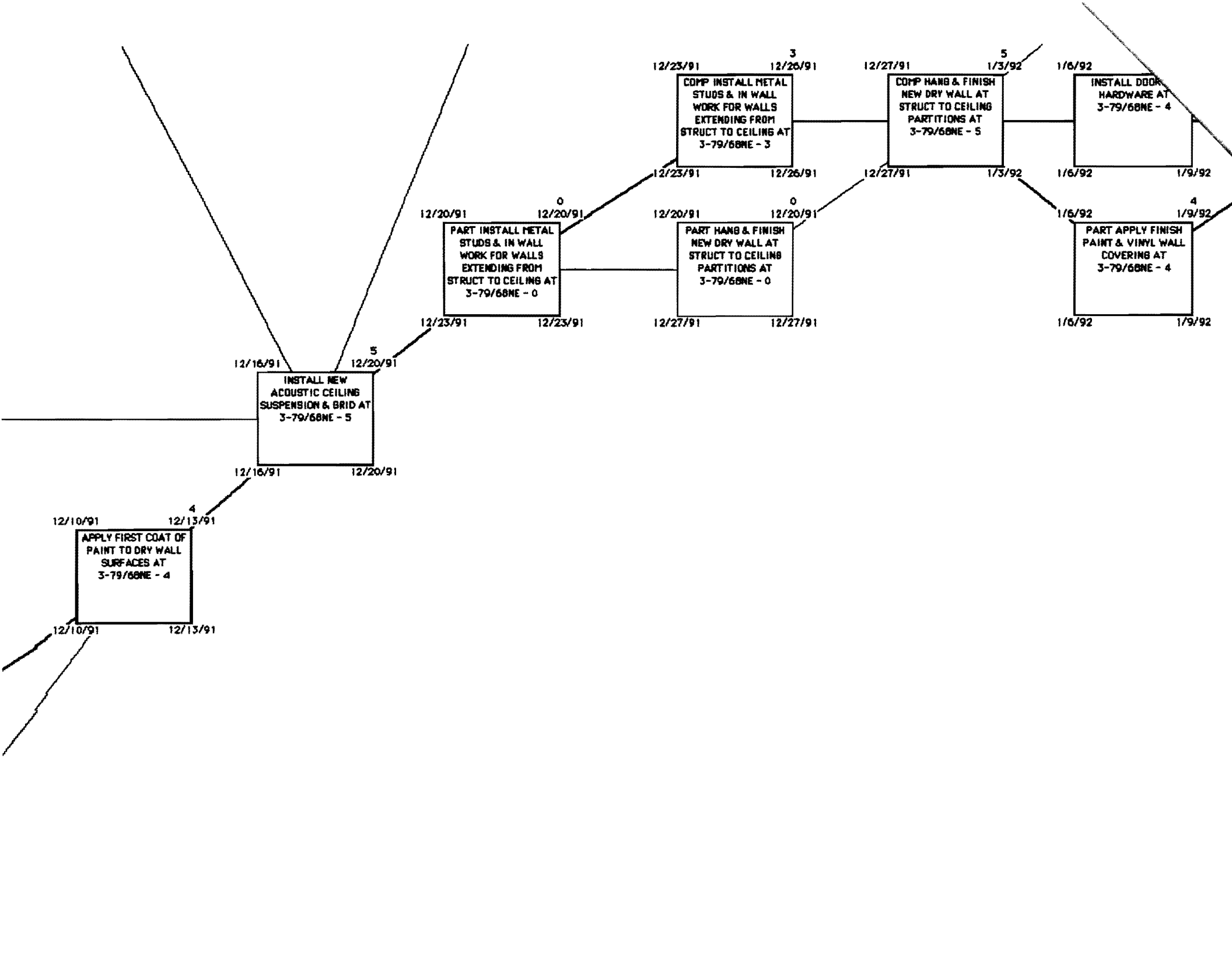

~~21~~
21

1-79

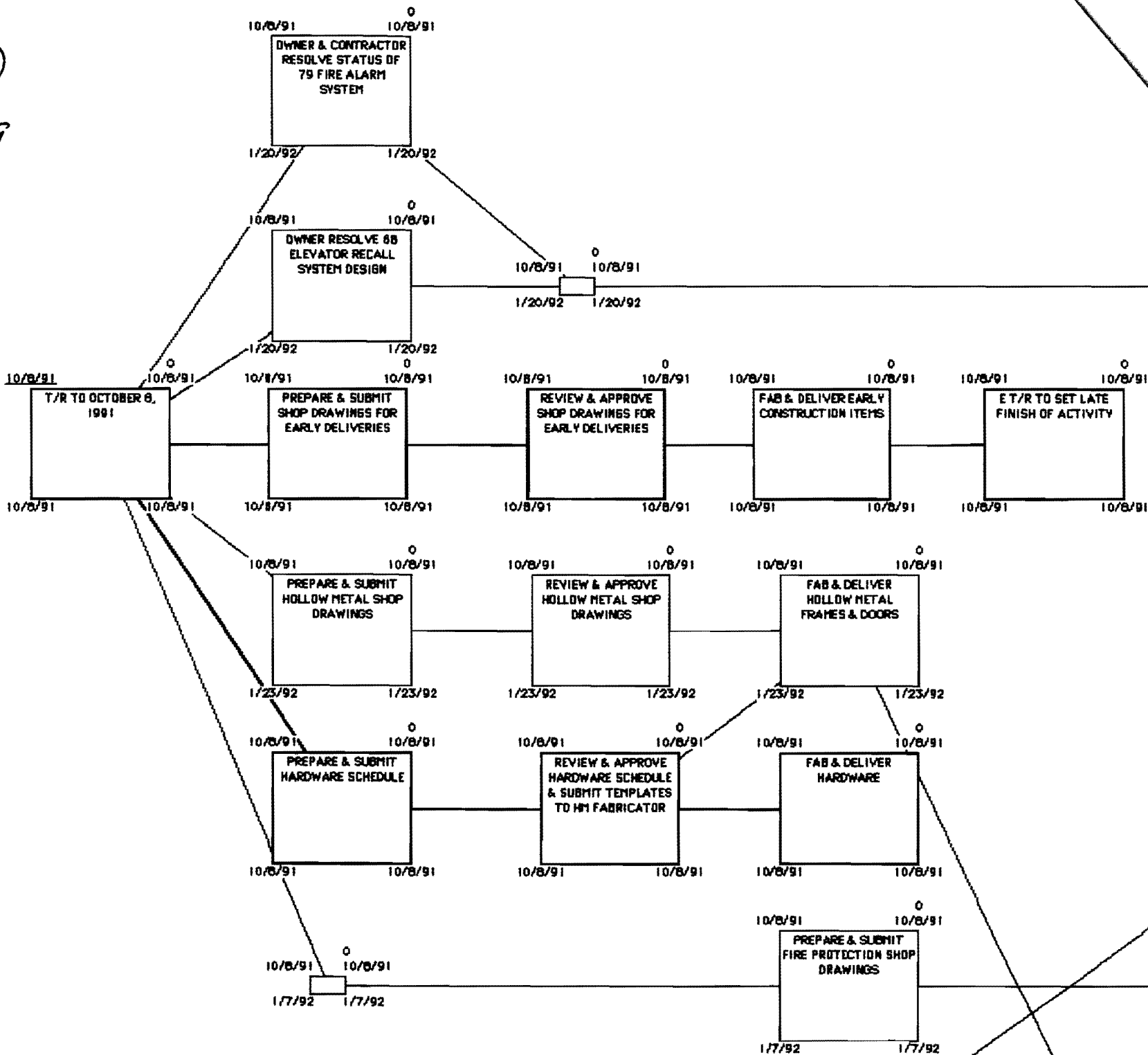

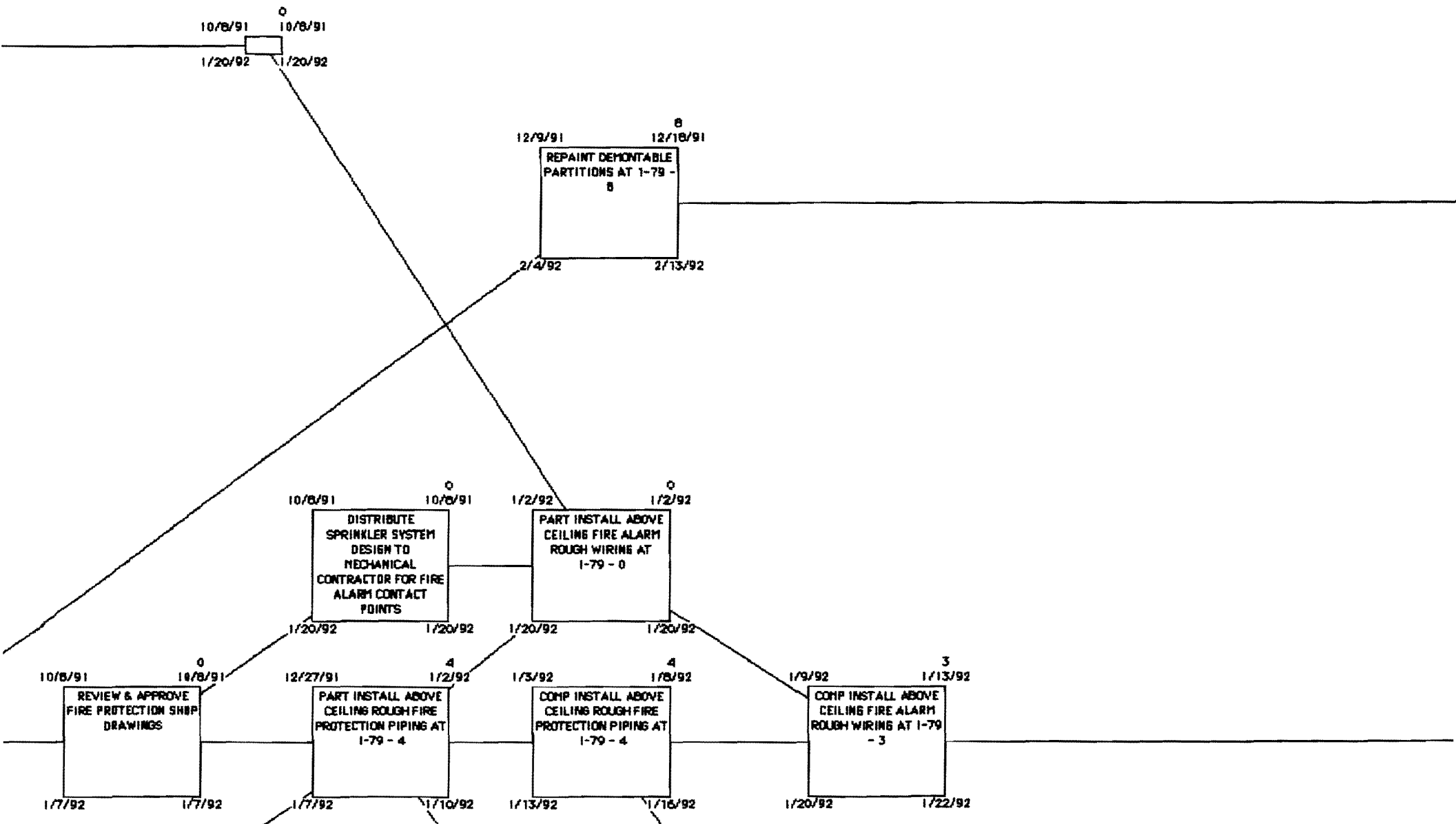

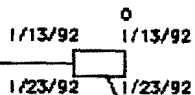
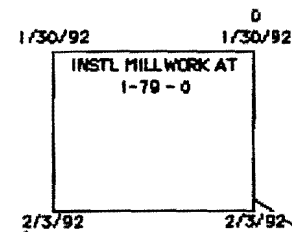
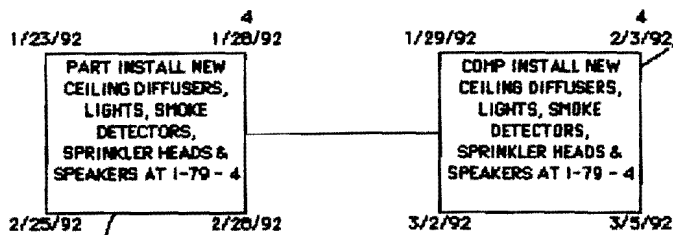
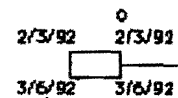
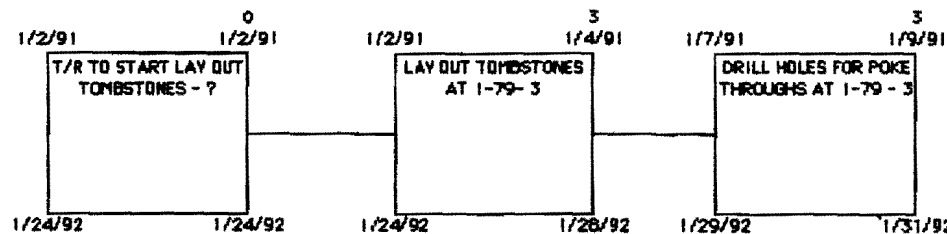
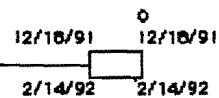

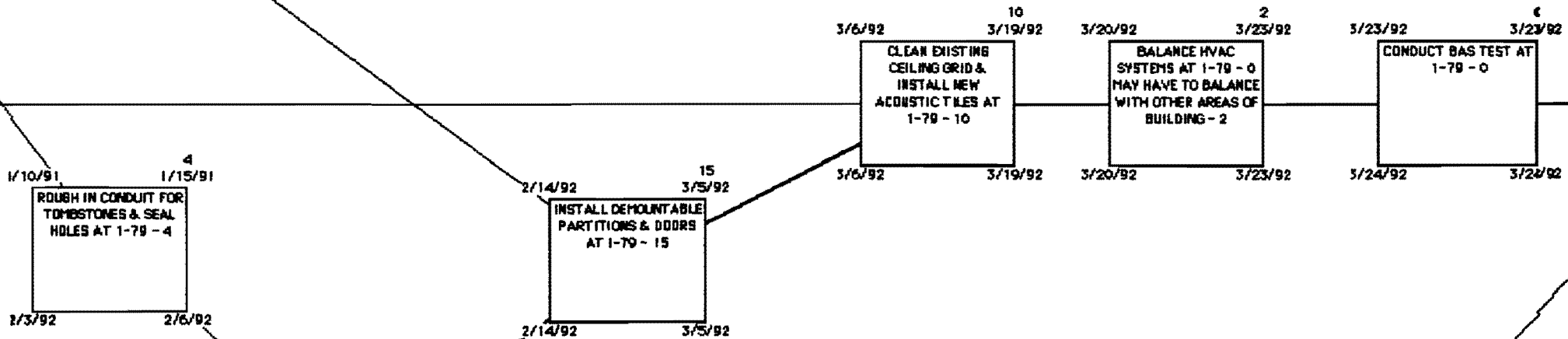
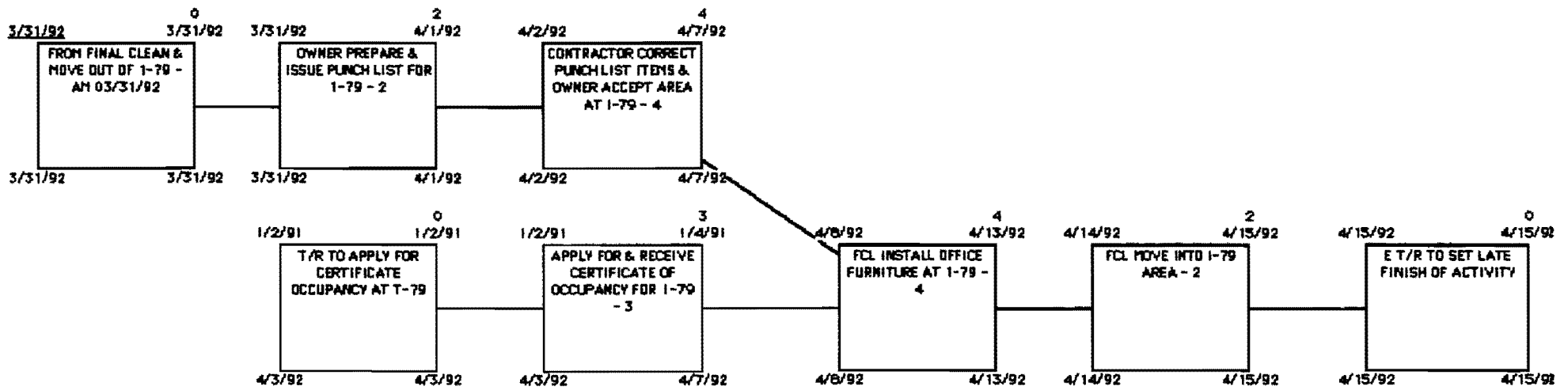

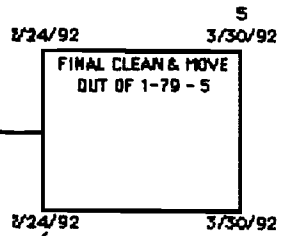

i7

1-79

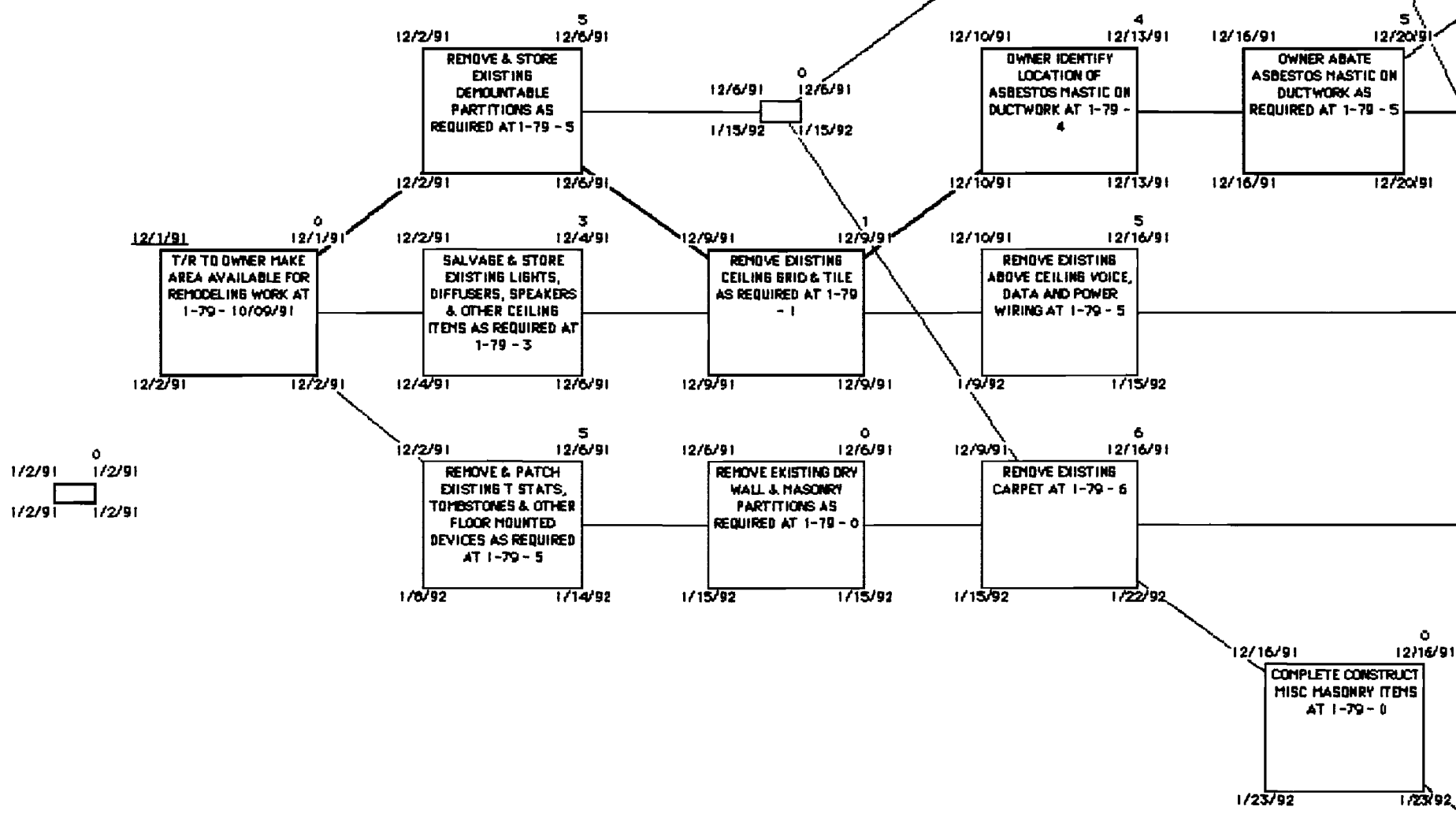

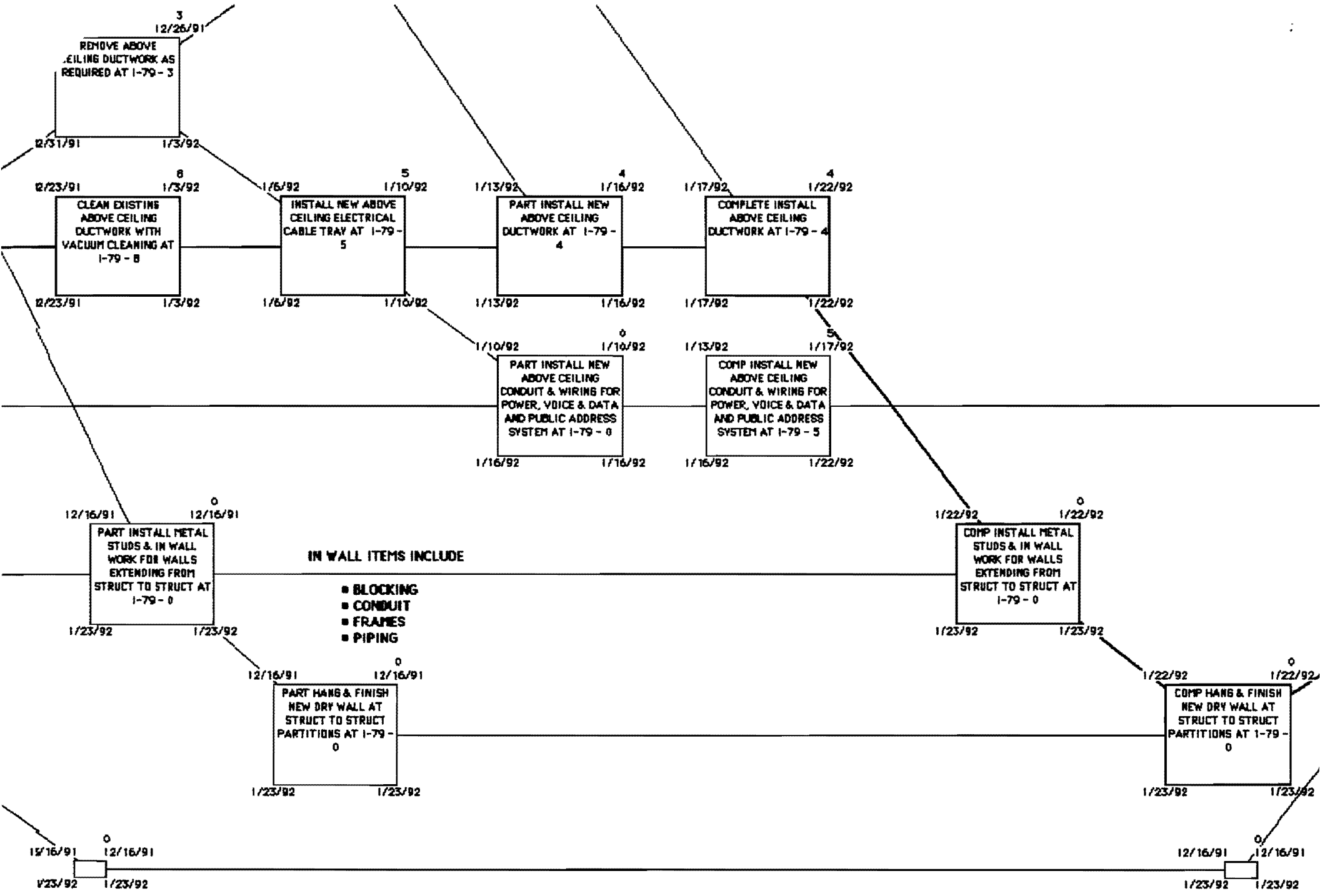

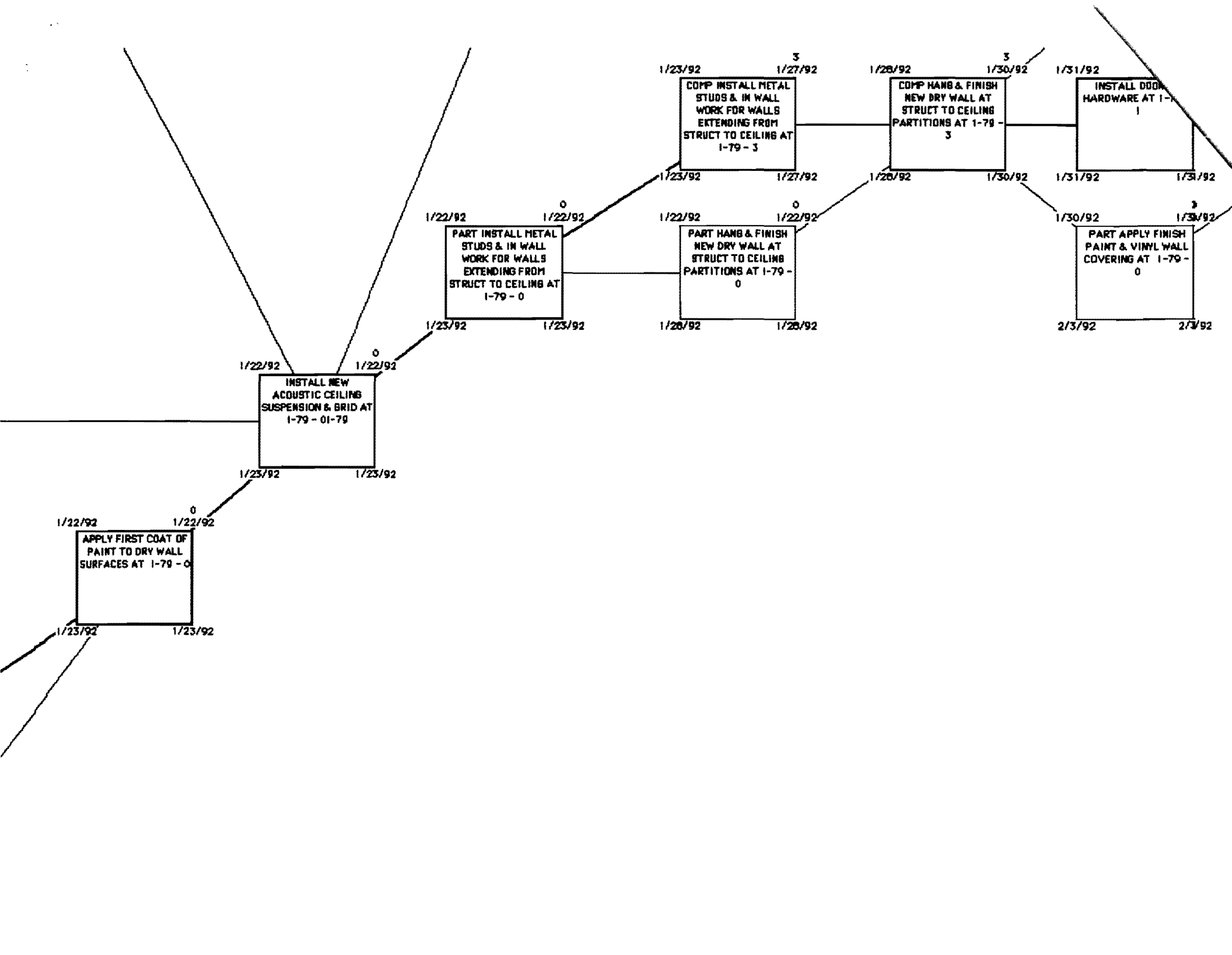

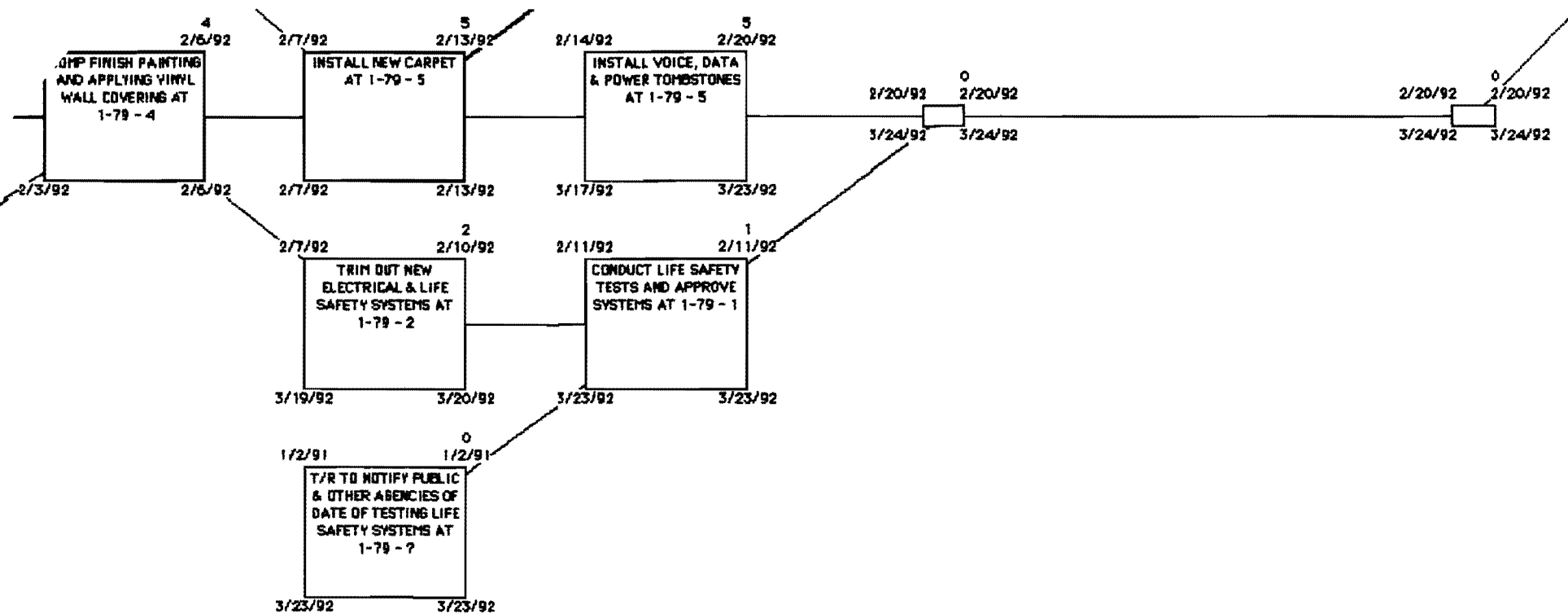

Interior work for area 1-79

NETWORK MODEL FOR FIRST COLONY LIFE INSURANCE COMPANY OFFICE ADDITION Lynchburg, Virginia

H. J. Construction Joint Venture
Lynchburg, Virginia 24506

Ralph J. Stephenson PE PE
Consulting Engineer
323 Hiawatha Drive
Mt. Pleasant, Michigan 48853
ph 517 772 2537

Early start Duration
 Early finish

11/14/90 11/15/90

03-SELECT NUMBER OF TEST PILES TO BE USED & LOCATION - 1 (example)

11/14/90 11/15/90

Late start Late finish

- Activity number
- Activity description
- Activity estimated duration in stepped working days

Reserved Activity Numbers

041 046
042 047
043 048
044 049
045 050

Issue #1 - October 9, 1991
1st edit# 1-79 int work
date 2/83

ACTIVITY

21
2-79/68

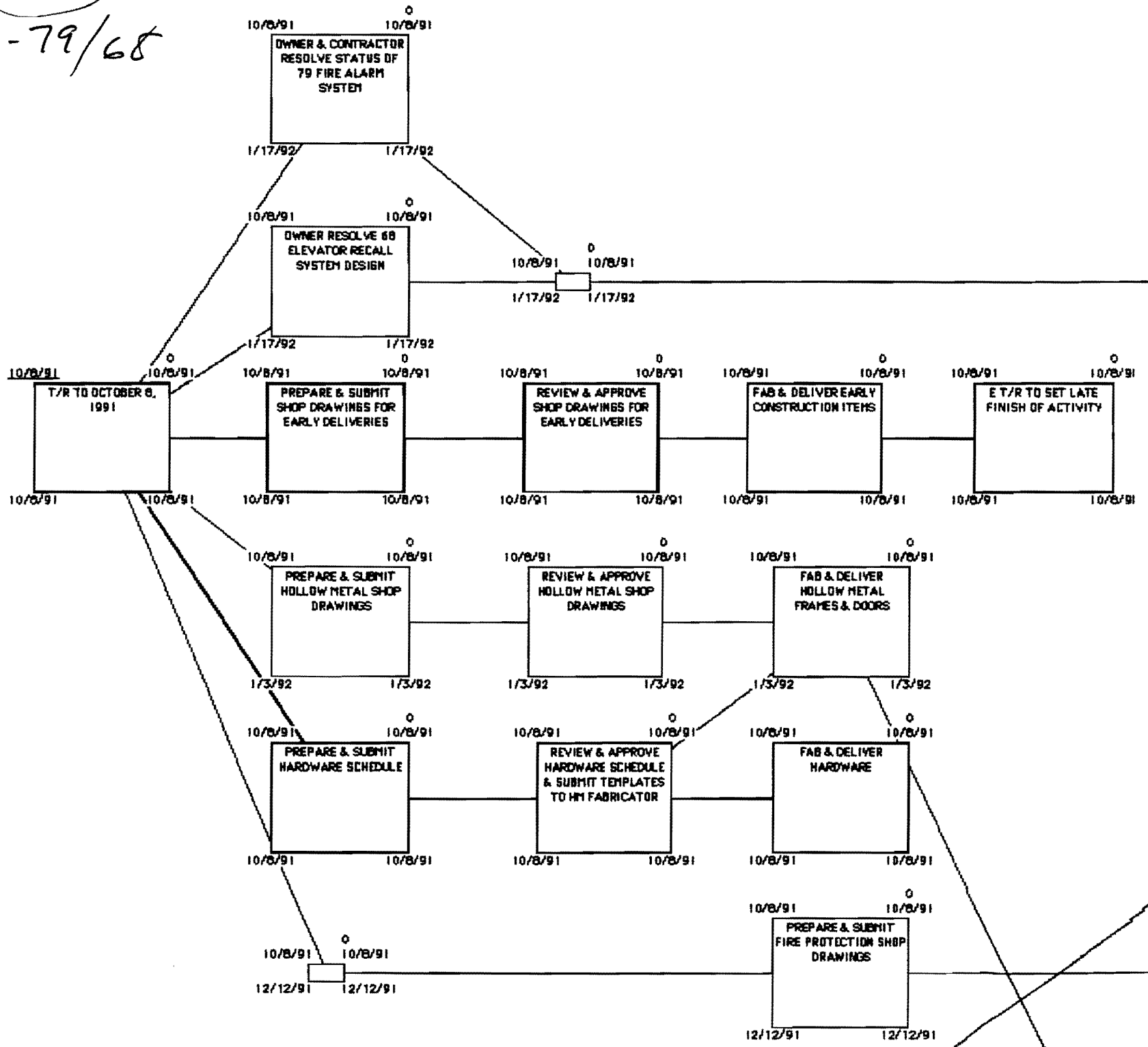

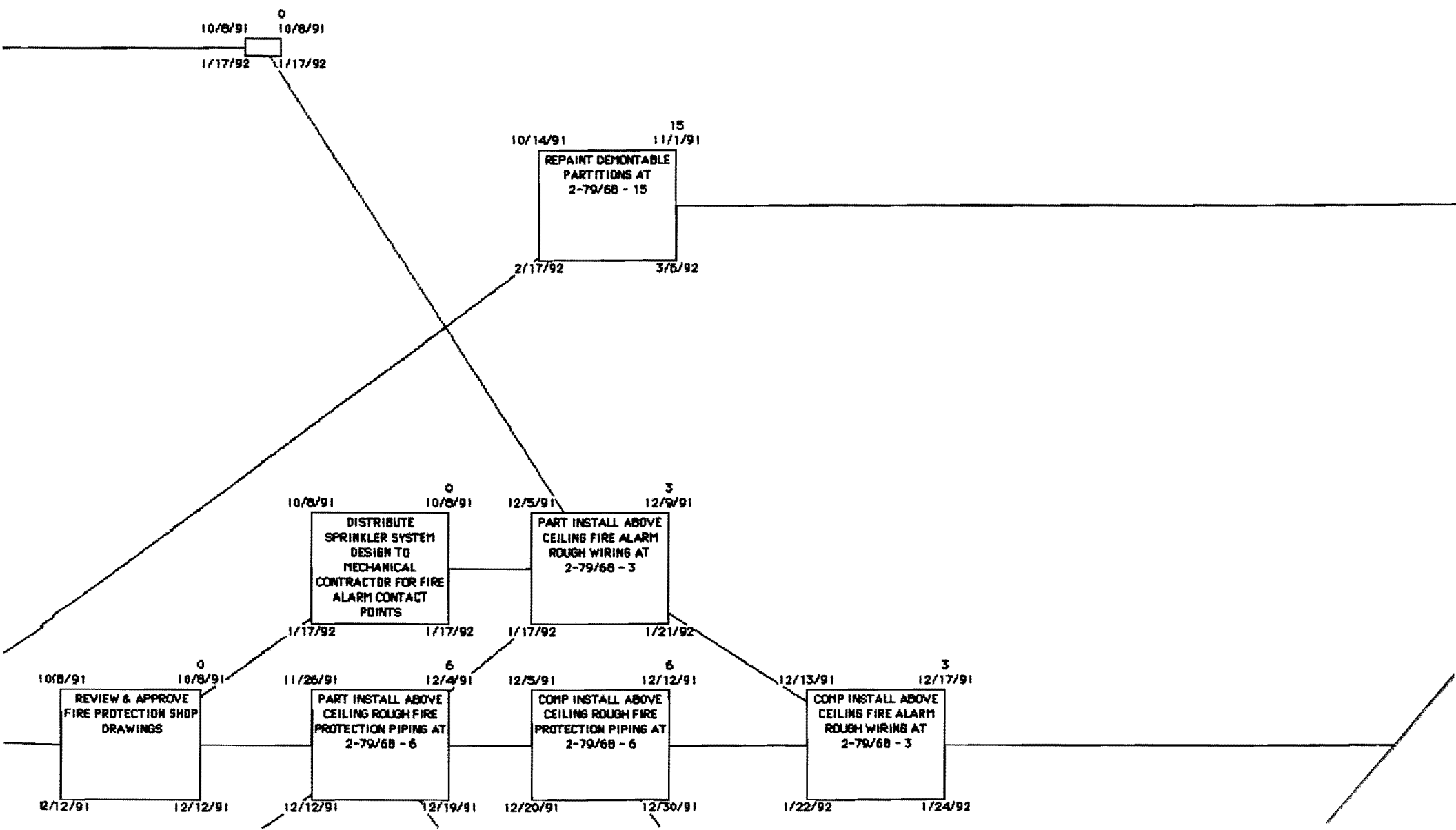

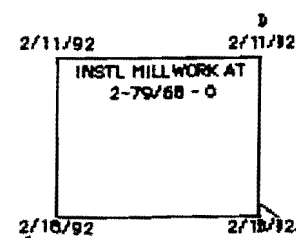
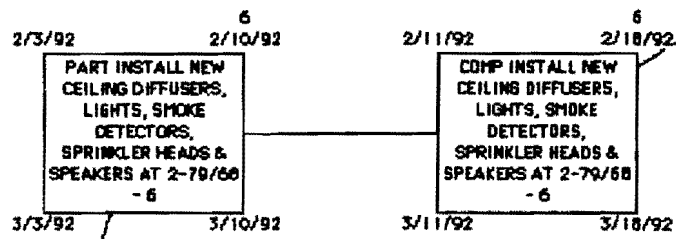
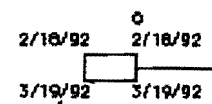
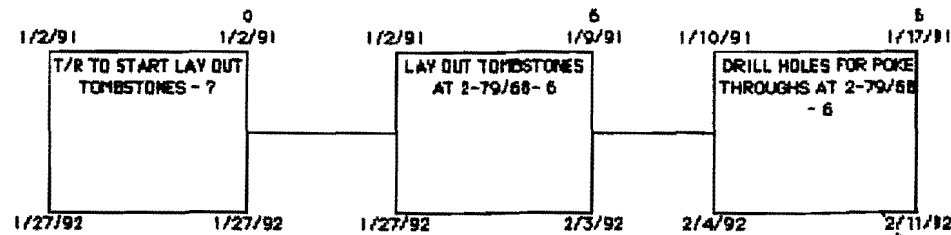
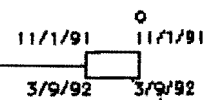
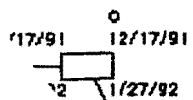

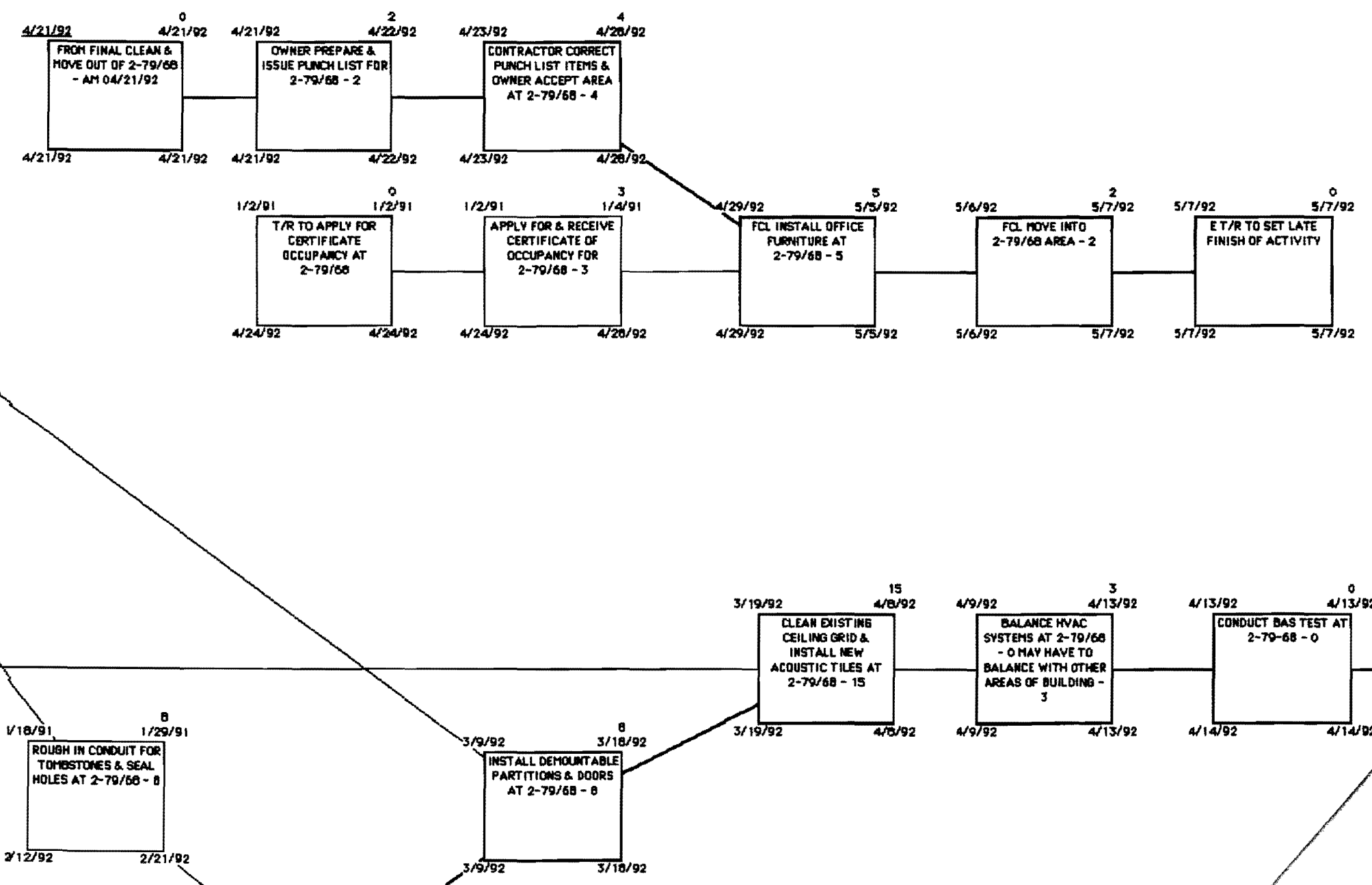

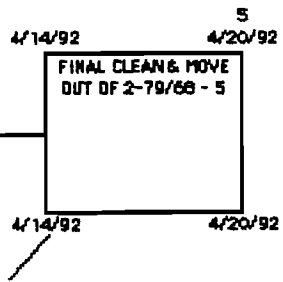

2-79/68

21

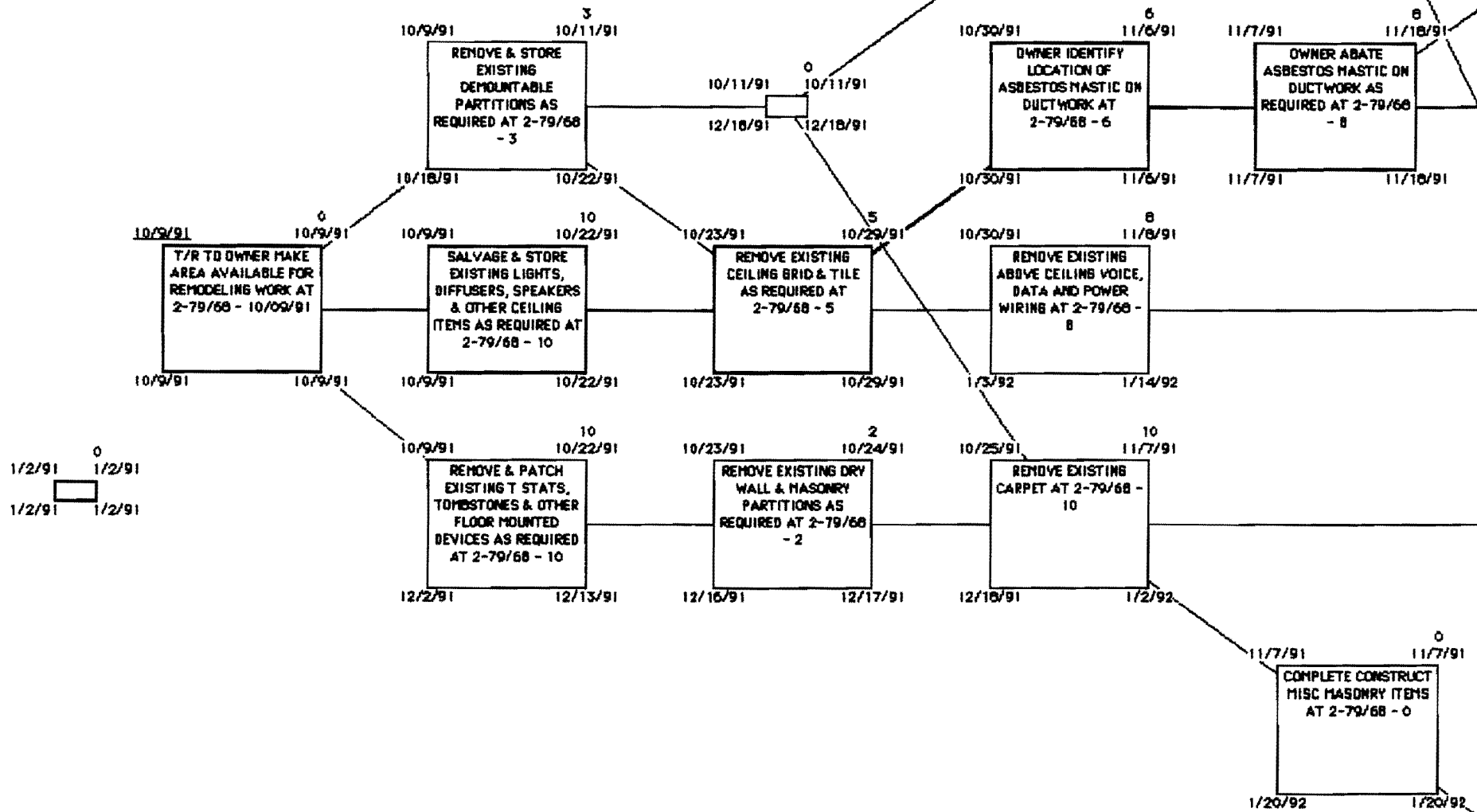

5
 11/19/91 11/25/91
 REMOVE ABOVE CEILING DUCTWORK AS REQUIRED AT 2-79/68 - 5

12
 11/19/91 12/5/91
 CLEAN EXISTING ABOVE CEILING DUCTWORK WITH VACUUM CLEANING AT 2-79/68 - 12

10
 12/6/91 12/19/91
 INSTALL NEW ABOVE CEILING ELECTRICAL CABLE TRAY AT 2-79/68 - 10

6
 12/20/91 12/30/91
 PART INSTALL NEW ABOVE CEILING DUCTWORK AT 2-79/68 - 6

6
 12/31/91 1/8/92
 COMPLETE INSTALL ABOVE CEILING DUCTWORK AT 2-79/68 - 6

4
 12/20/91 12/26/91
 PART INSTALL NEW ABOVE CEILING CONDUIT & WIRING FOR POWER, VOICE & DATA AND PUBLIC ADDRESS SYSTEM AT 2-79/68 - 4

4
 12/27/91 1/2/92
 COMP INSTALL NEW ABOVE CEILING CONDUIT & WIRING FOR POWER, VOICE & DATA AND PUBLIC ADDRESS SYSTEM AT 2-79/68 - 4

3
 11/8/91 11/12/91
 PART INSTALL METAL STUDS & IN WALL WORK FOR WALLS EXTENDING FROM STRUCT TO STRUCT AT 2-79/68 - 3

IN WALL ITEMS INCLUDE

- BLOCKING
- CONDUIT
- FRAMES
- PIPING

3
 1/9/92 1/13/92
 COMP INSTALL METAL STUDS & IN WALL WORK FOR WALLS EXTENDING FROM STRUCT TO STRUCT AT 2-79/68 - 3

4
 11/13/91 11/18/91
 PART HANG & FINISH NEW DRY WALL AT STRUCT TO STRUCT PARTITIONS AT 2-79/68 - 4

4
 1/14/92 1/17/92
 COMP HANG & FINISH NEW DRY WALL AT STRUCT TO STRUCT PARTITIONS AT 2-79/68 - 4

0
 11/7/91 11/7/91
 1/20/92 1/20/92

0
 11/7/91 11/7/91
 1/20/92 1/20/92

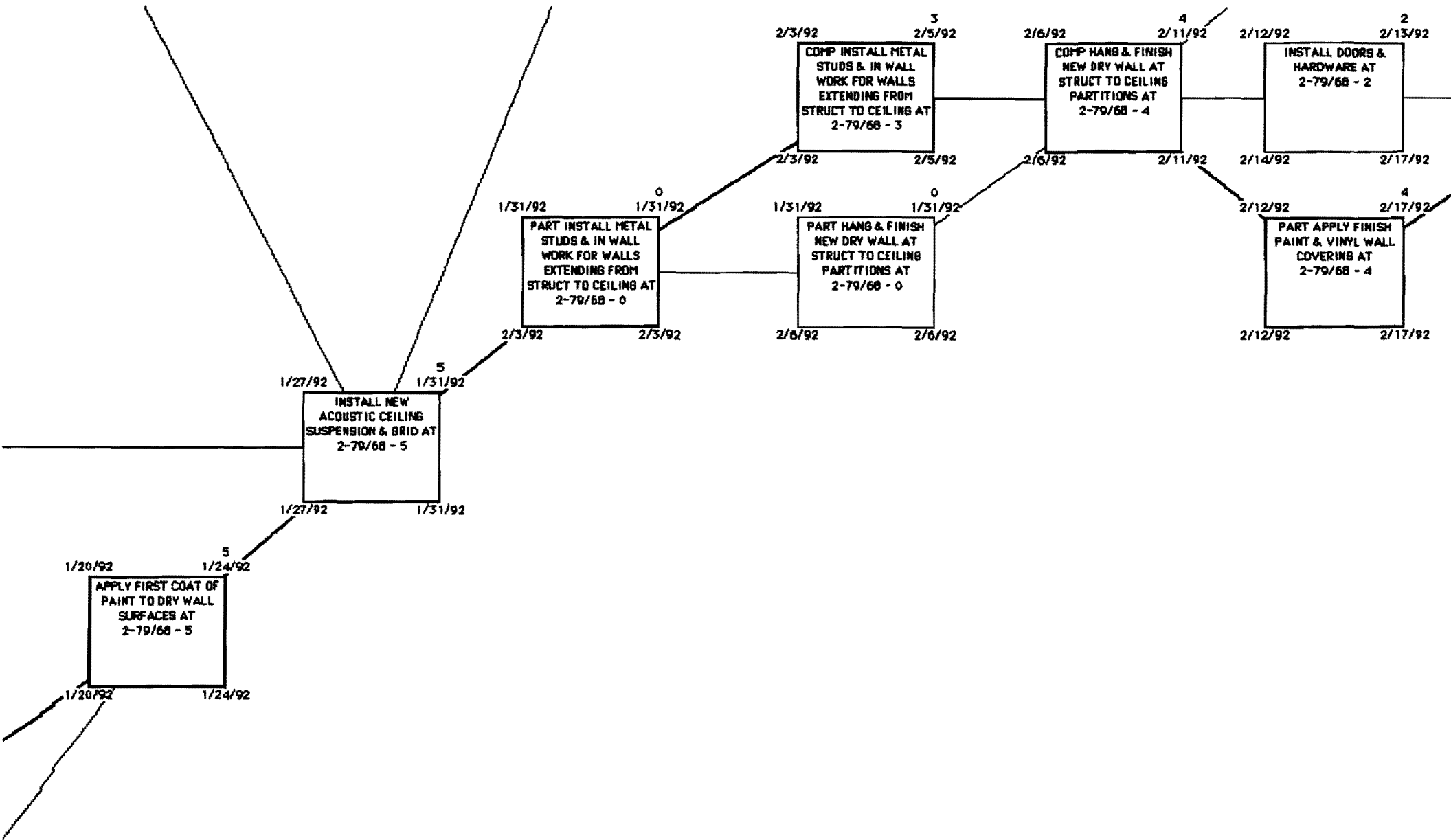

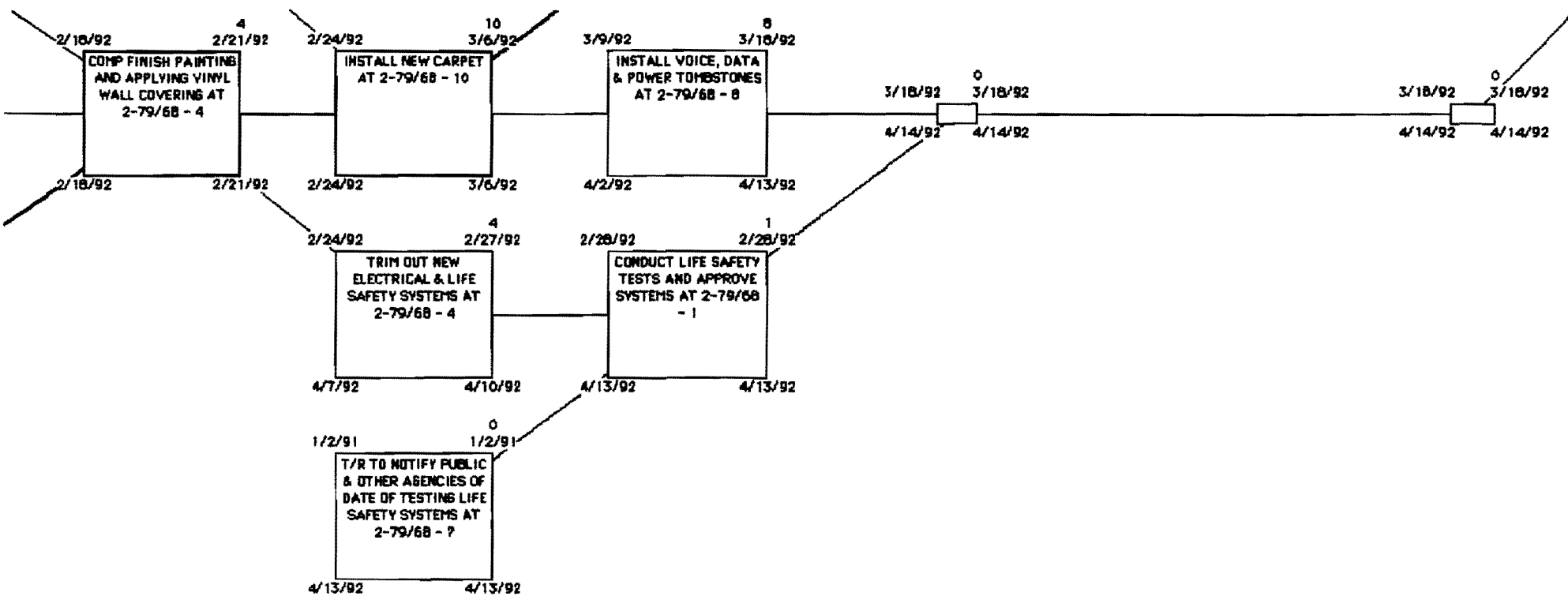

Interior work for area 2-79/68

NETWORK MODEL FOR FIRST COLONY LIFE INSURANCE COMPANY OFFICE ADDITION Lynchburg, Virginia

H. J. Construction Joint Venture Lynchburg, Virginia 24506

Ralph J. Stephenson PE PE
 Consulting Engineer
 323 Hiawatha Drive
 Mt. Pleasant, Michigan 48853
 ph 517 772 2537

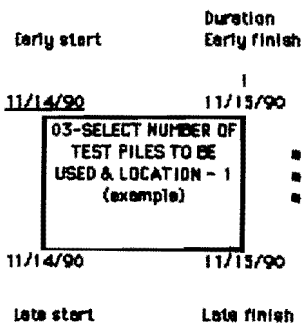

- Activity number
- Activity description
- Activity estimated duration in stepped working days

Reserved Activity Numbers

041	046
042	047
043	048
044	049
045	050

Issue #1 - October 9, 1991
 11/14/90 mt work
 dia: 203

ACTIVITY

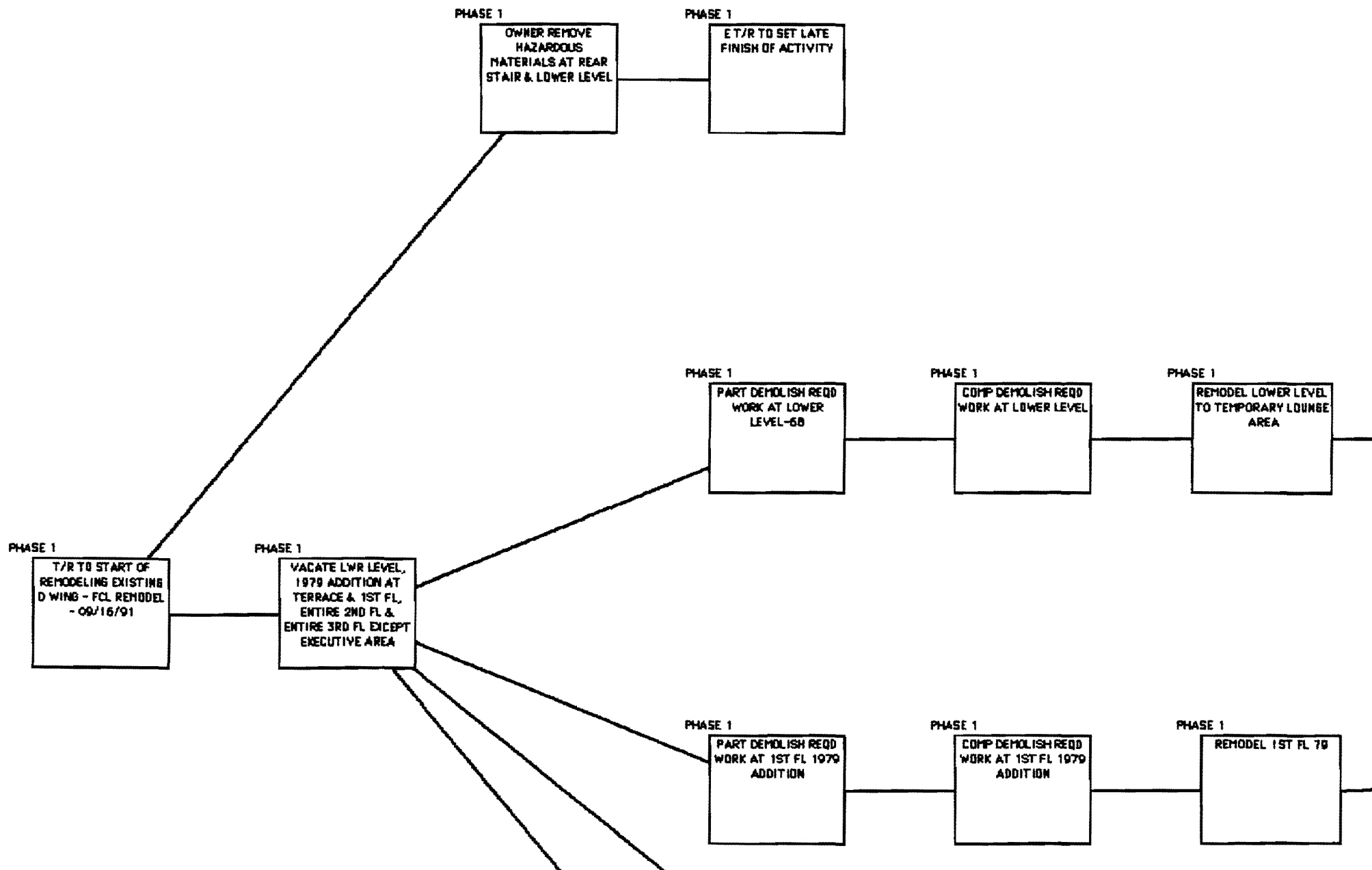

PHASE 1

FCL MOVE INTO TEMP
LOUNGE FROM TERRACE
LEVEL 1979 ADDITION

PHASE 1

DEMOLISH REQD WORK
AT TERRACE LEVEL-79

PHASE 1

REMODEL TERRACE
LEVEL-79

PHASE 1

MOVE LUNCH ROOM
FROM LOWER LEVEL TO
REMODELED TERRACE
LEVEL - 1979
ADDITION

PHASE 1

E T/R TO SET
COMPLETION DATE OF
LUNCH ROOM MOVE

PHASE 1

COMPLETE ALL
TERRACE LEVEL
REMODELING AT 1979
ADDITION

PHASE 1

MOVE CENTRAL FILES
FROM TERRACE LEVEL
AT 1968 REMODELED
AREA TO NEW TERRACE
LEVEL - 1979
ADDITION

PHASE 1

E T/R TO SET LATE
FINISH OF CENTRAL
FILE MOVE



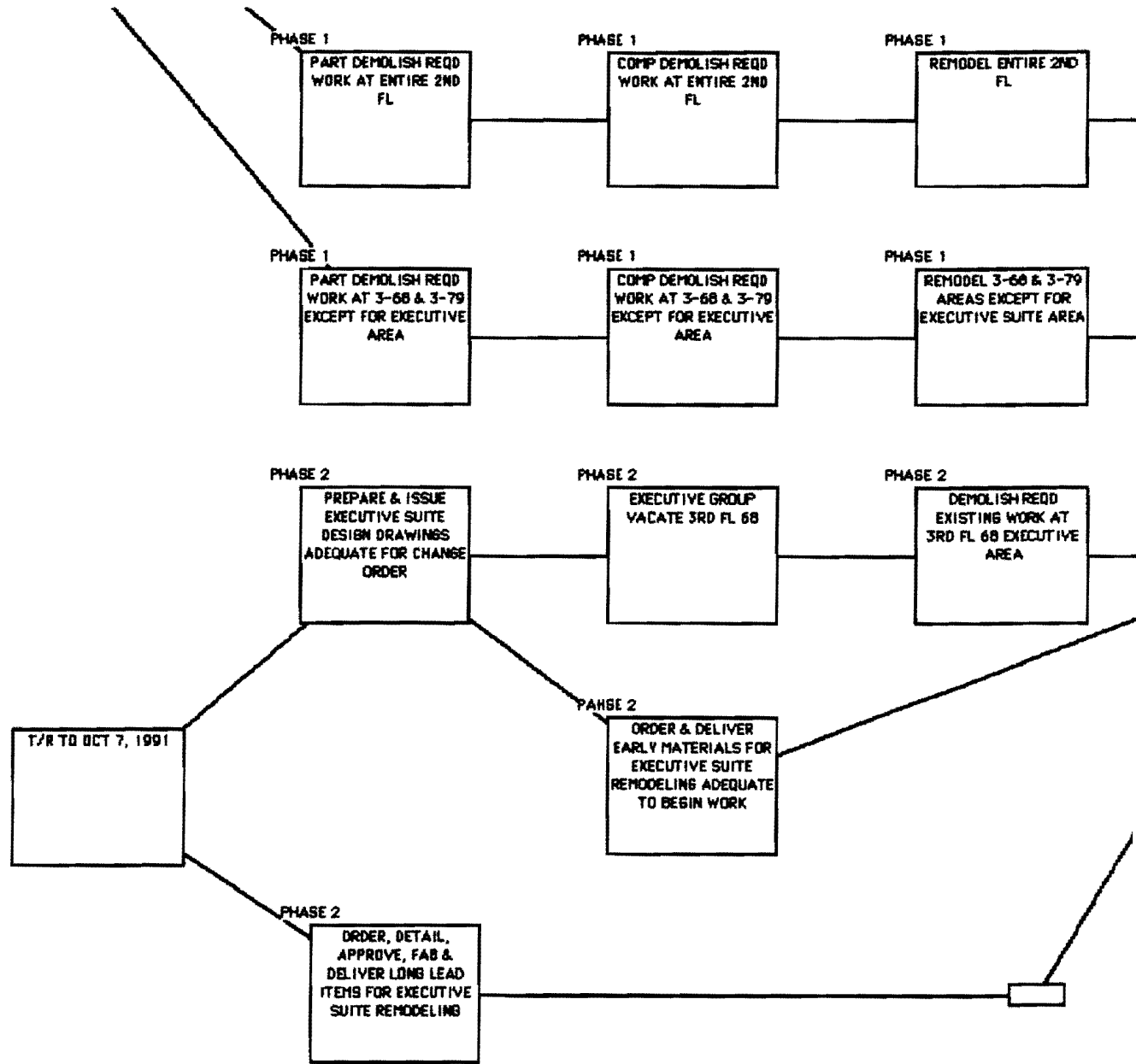

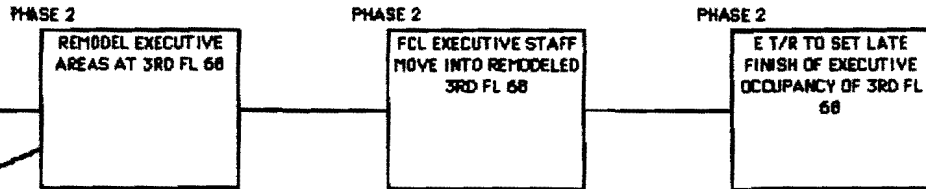
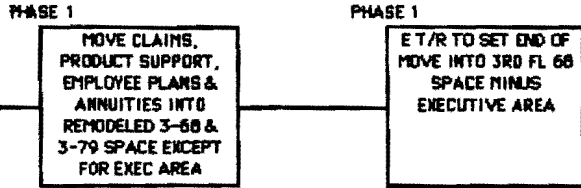
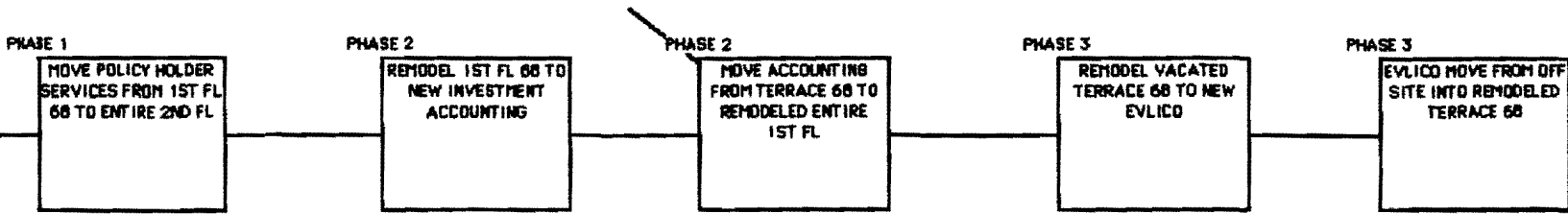

51
SUMMARY
FCL2

Total float time Duration
Early start Early finish

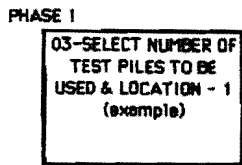

- Activity number
- Activity description
- Activity estimated duration in elapsed working days

Late start Late finish



Reserved Activity Numbers

- 041 046
- 042 047
- 043 048
- 044 049
- 045 050

Issue #1 - October 7, 1991
light #1 1d12 entry move plan
disk 282

**NETWORK MODEL FOR FIRST
COLONY LIFE INSURANCE
COMPANY OFFICE ADDITION
Lynchburg, Virginia**

**H. J. Construction Joint Venture
Lynchburg, Virginia 24506**

Ralph J. Stephenson PE PE
Consulting Engineer
323 Hiawatha Drive
Mt. Pleasant, Michigan 48853
ph 517 772 2537