

PLAN OF WORK USING ONE TEAM OF FINISH TRADES WORKERS.

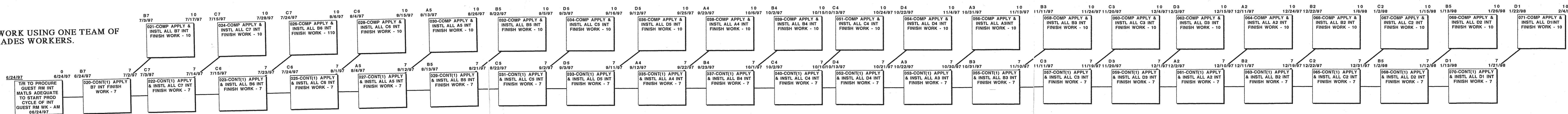

Guest room interior work sequence as of 10/18/96

- B2 to B3 to B4 to B5 to B6 to B7 for remainder of gyp board work. (up)
- B7 to C7 to B6 to C6 to A5 to B5 to C5 to D5 to A4 to B4 to C4 to D4 to A3 to B3 to C3 to A2 to B2 to C2 to D2 for remainder of interior finish work. (down)

PLAN OF WORK USING TWO TEAMS OF FINISH TRADES WORKERS.

- TEAM A - FROM B7 - C7 - A5 - B5 - C5 - D5 - A3 - B3 - C3 - D3 - D1
- TEAM B - FROM B6 - C6 - A4 - B4 - C4 - D4 - A2 - B2 - C2 - D2

TEAM A WORK

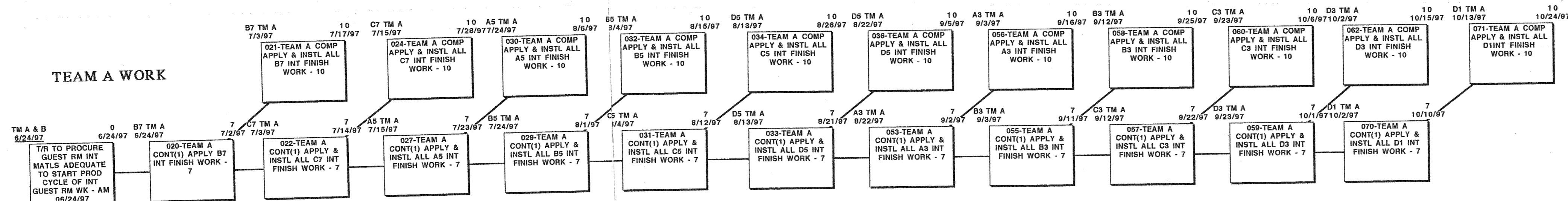

TEAM A WORK

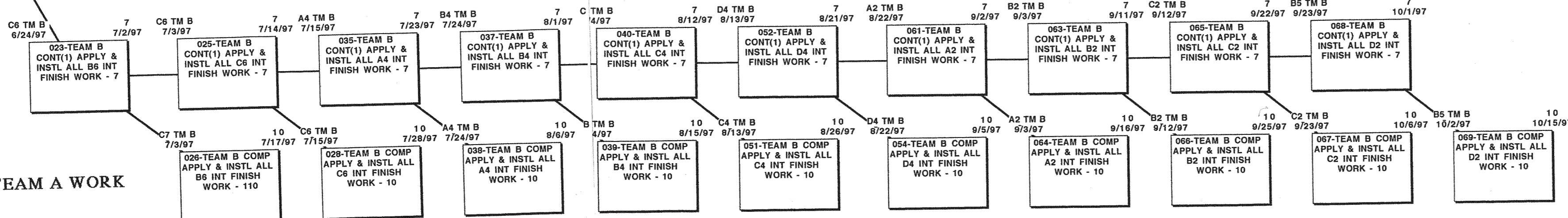

Subtitle Earliest Start Duration Earliest Finish

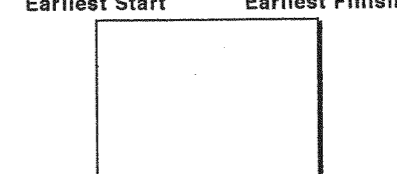

Issue #1 through 10 - not issued
Issue #11 - October 15, 1996
Issue #12 - October 19, 1996
i12 sht SM1

SUMMARY MODEL FOR HOTEL INTERIOR WORK - FLOORS 2 THROUGH 7

ACTIVITY KEY

NETWORK MODEL FOR SOARING EAGLE RESORT - Chippewa Indian Tribe of Michigan - Mt. Pleasant, Michigan

Reserved Activity Numbers

041	046	091	096
042	047	092	097
043	048	093	098
044	049	094	099
045	050	095	100

LAN 001
HAN ?

Perini Building Company and Shingobee Builders
Southfield, Michigan

Ralph J. Stephenson, P.E., P.C.
Consulting Engineer
323 Hiawatha Drive
Mt. Pleasant, Michigan, 48858
ph 517 772 2537

SHEET SM1

Note: This network model is based on one shift working 5 days per week and 8 hours per day. Non working days include Saturdays, Sundays, and September 4, 1995, November 23, 1995, December 25, 1995, January 1, 1996, May 27, 1996, July 4, 1996, September 2, 1996, November 28, 1996, and December 25, 1996.

Float time shown in this network model is for the sole use of Perini Building Company, U.S. Central District and is not to be used by others unless specifically approved in writing by Perini.

This network model has been prepared from information available to Perini/Shingobee as of October 15, 1996. As the project proceeds and additional information becomes available the network models and schedules may require revisions and updating. When this is necessary Perini/Shingobee will, with the cooperation of its staff and subcontractors, and with the assistance of the owner, update the network models and schedules to reflect current available information.

AREA B - 6TH FLOOR

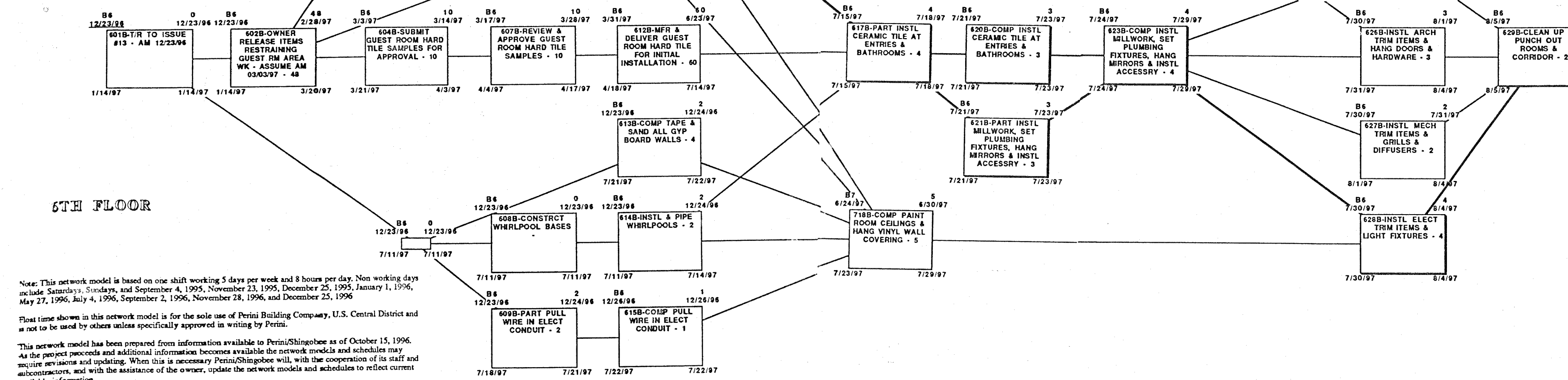

5TH FLOOR

Note: This network model is based on one shift working 5 days per week and 8 hours per day. Non working days include Saturdays, Sundays, and September 4, 1995, November 23, 1995, December 25, 1995, January 1, 1996, May 27, 1996, July 4, 1996, September 2, 1996, November 28, 1996, and December 25, 1996.

Float time shown in this network model is for the sole use of Perini Building Company, U.S. Central District and is not to be used by others unless specifically approved in writing by Perini.

This network model has been prepared from information available to Perini/Shingobee as of October 15, 1996. As the project proceeds and additional information becomes available the network models and schedules may require revisions and updating. When this is necessary Perini/Shingobee will, with the cooperation of its staff and subcontractors, and with the assistance of the owner, update the network models and schedules to reflect current available information.

AREA C - 6TH FLOOR

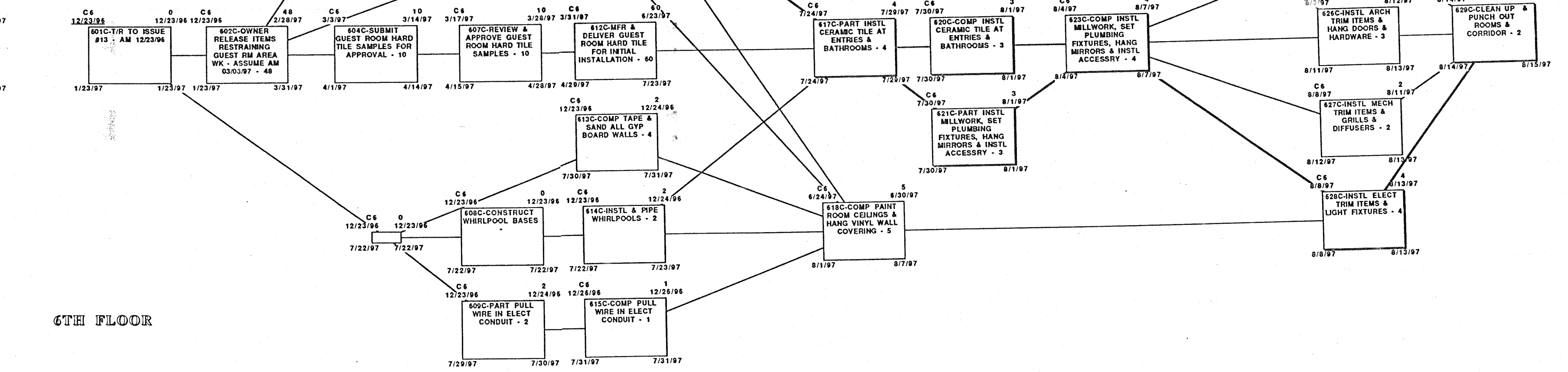

6TH FLOOR

Guest room interior work sequence as of 10/15/96

- B2 to B3 to B4 to B5 to B6 to B7 for remainder of gyp board (up)
- B7 to C7 to B6 to C6 to A5 to B5 to C5 to D5 to A4 to B4 to C4 to D4 to A3 to B3 to C3 to C2 to A2 to B2 to C2 to D2 for remainder of interior finish work. (down)

ACTIVITY KEY

Issue #1 through #11 - not issued
Issue #12 - October 18, 1996
Issue #13 - December 28, 1996
#13 sh #1

HOTEL DRY WALL WORK FOR GUEST FLOORS 7, 6, AND 5

NETWORK MODEL FOR SOARING EAGLE RESORT - Chippewa Indian Tribe of Michigan - Mt. Pleasant, Michigan

Perini Building Company and Shingobee Builders Southfield, Michigan

Ralph J. Stephenson, P.E., P.C. Consulting Engineer
323 Hiawatha Drive
Mt. Pleasant, Michigan, 48858
ph 517 772 2537

LAN 001	041	046	051	056
HAN 7	042	047	052	057
	043	048	053	058
	044	049	054	059
	045	050	055	100

Reserved Activity Numbers

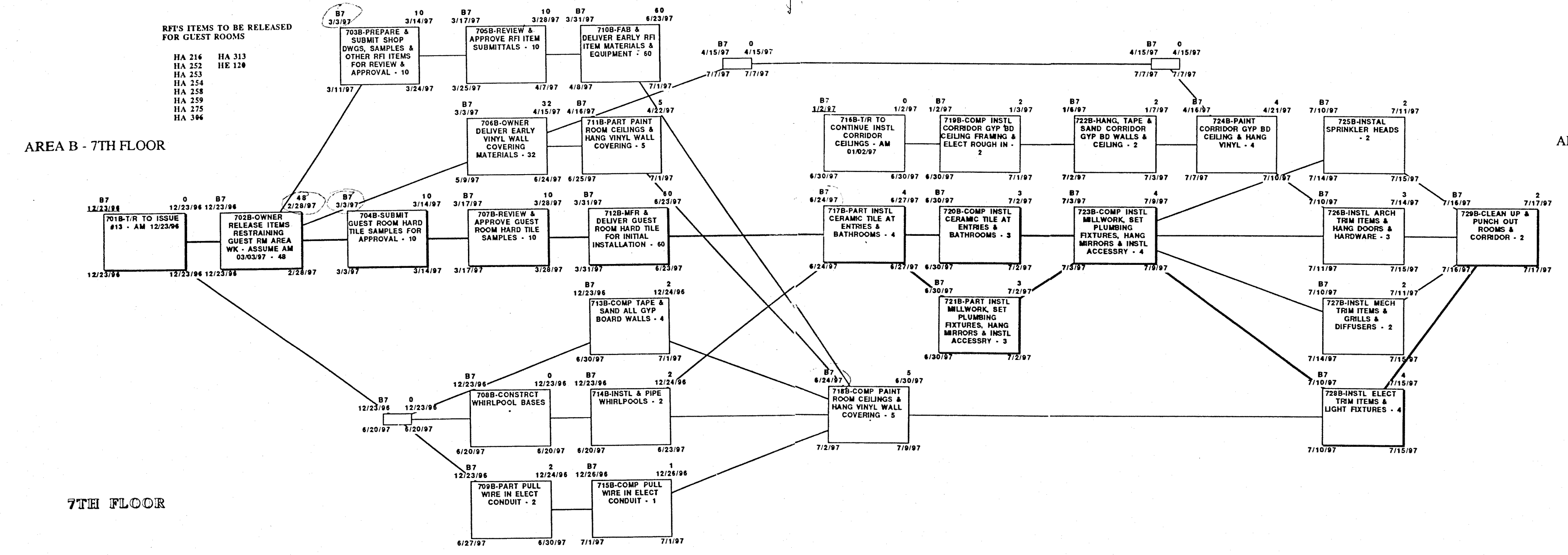

AREA C - 7TH FLOOR

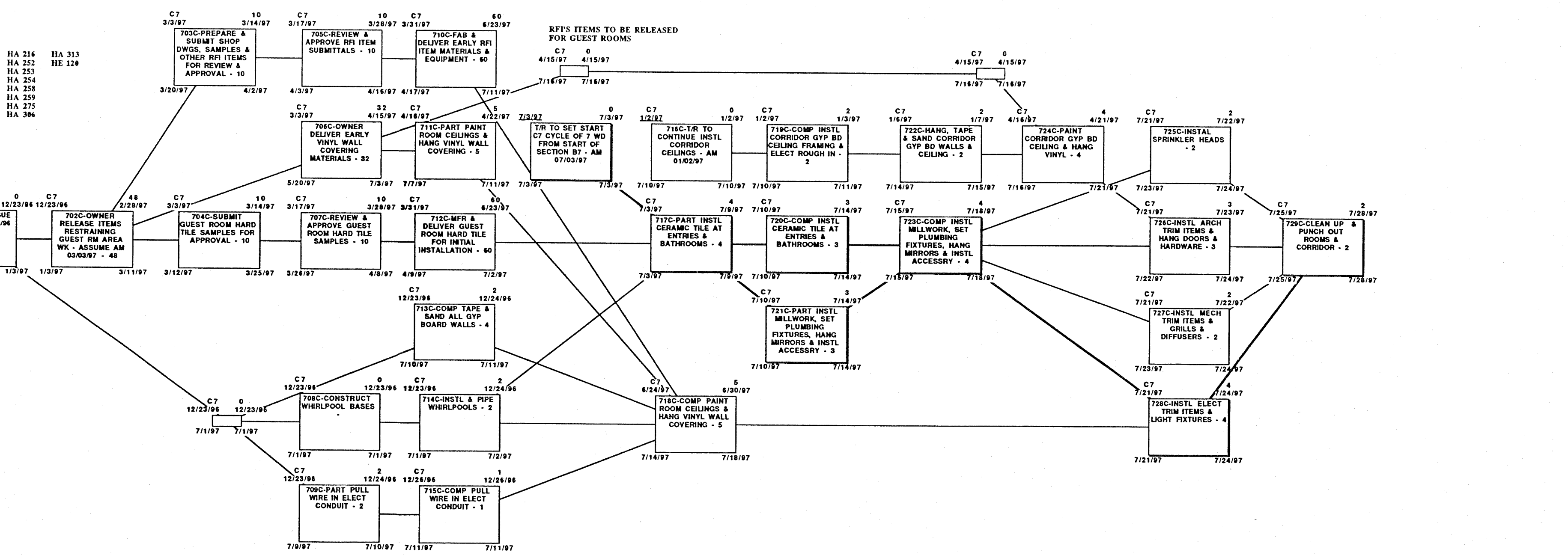

2ND FLOOR GUEST ROOMS
INTERIOR PLAN OF WORK

AREA A - 2ND FLOOR
TEAM B

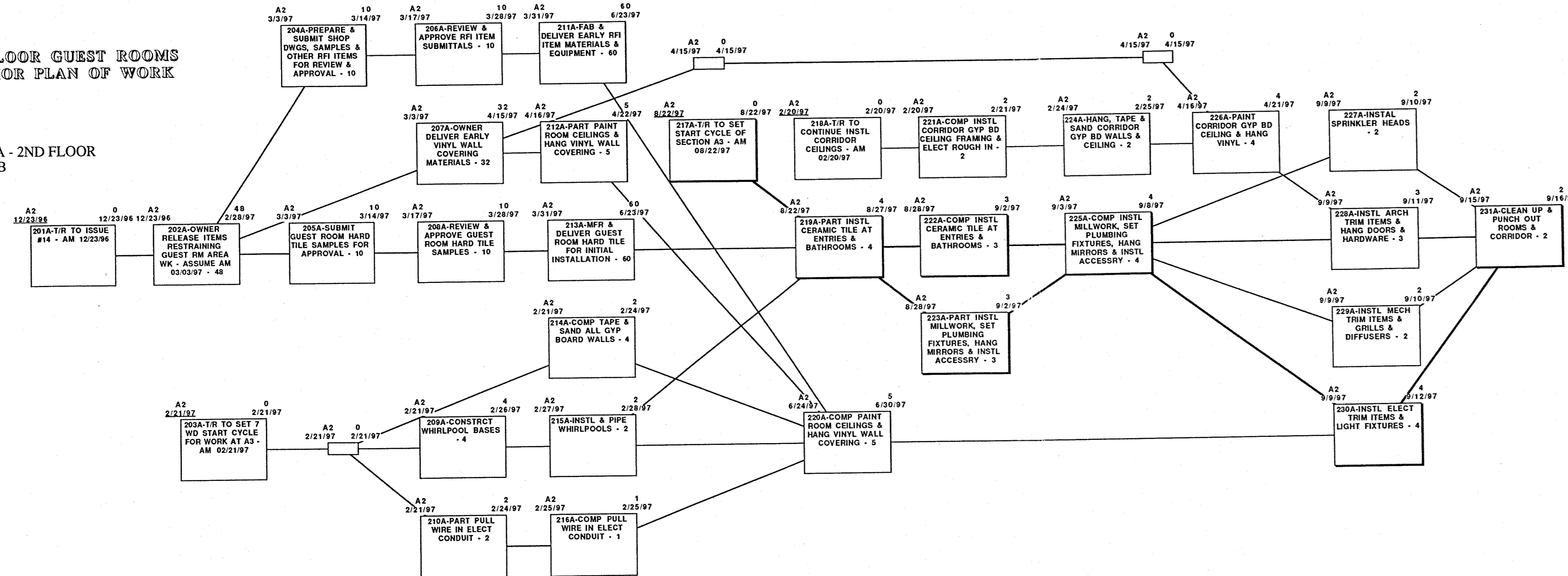

AREA B - 2ND FLOOR
TEAM B

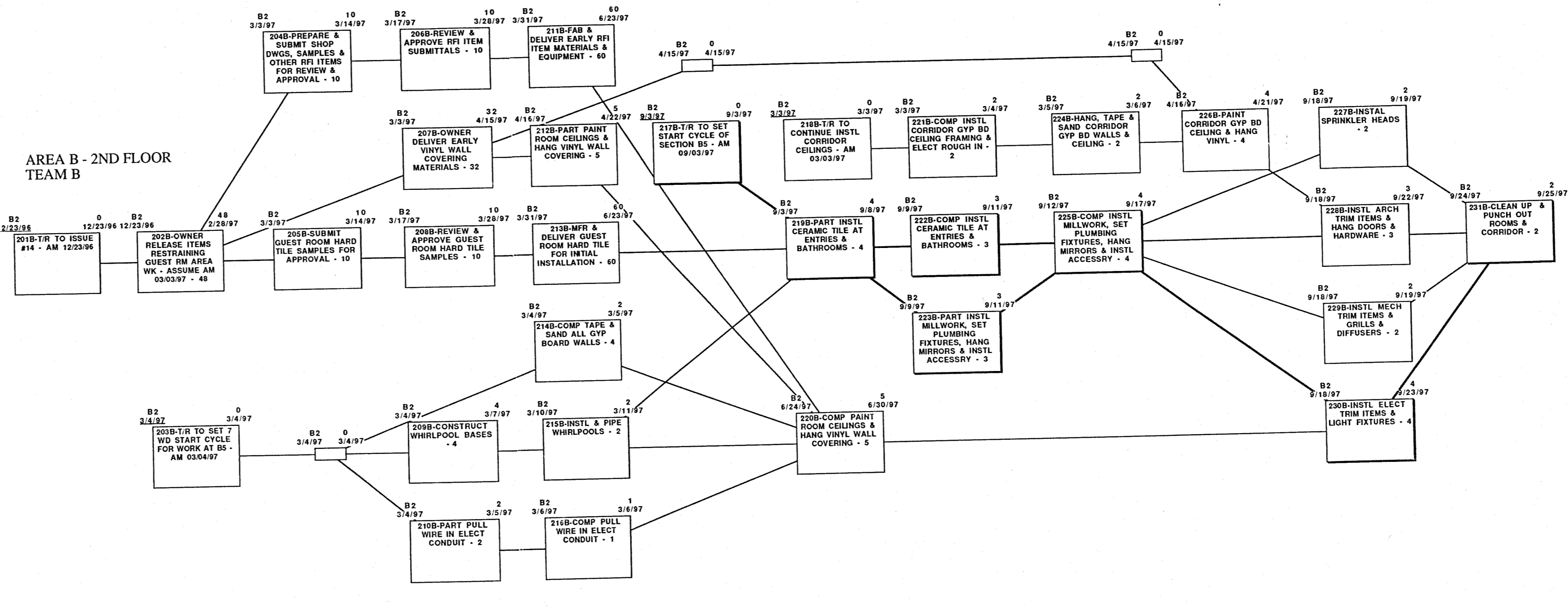

AREA C - 2ND FLOOR
TEAM B

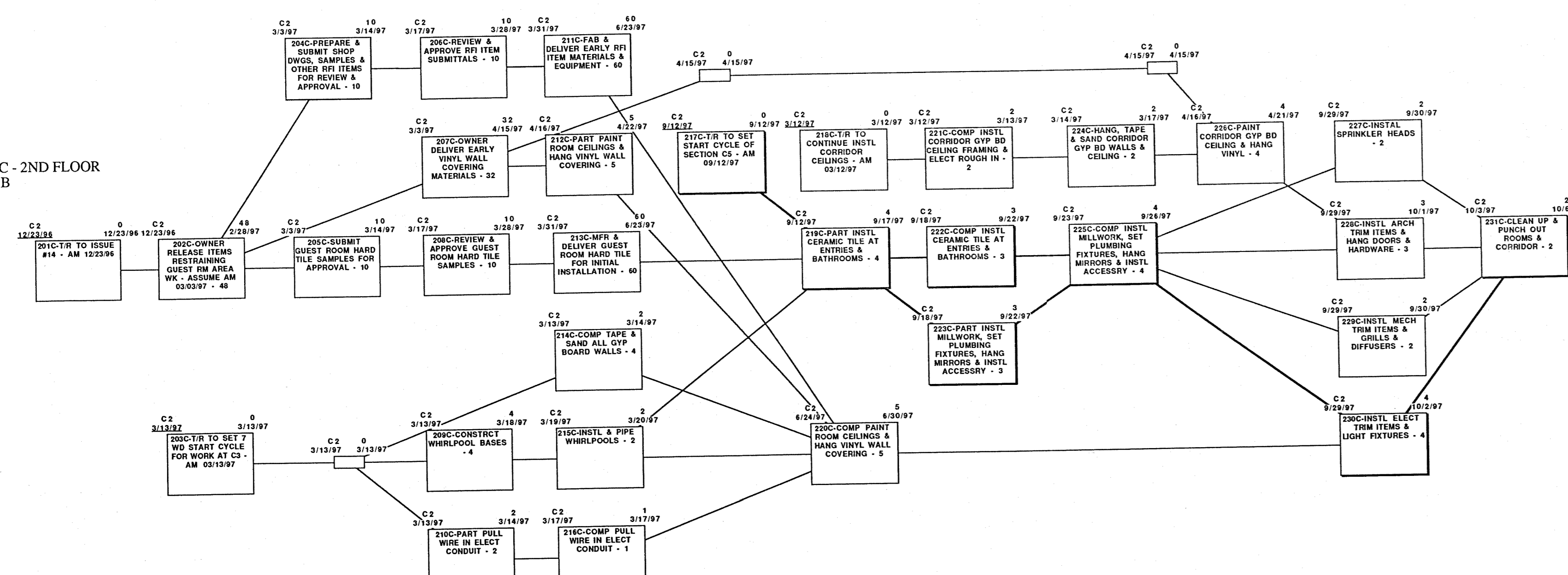

AREA D - 2ND FLOOR
TEAM B

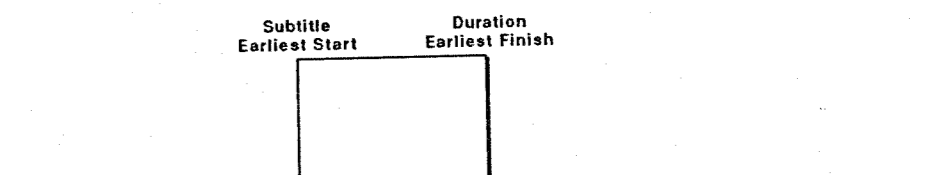
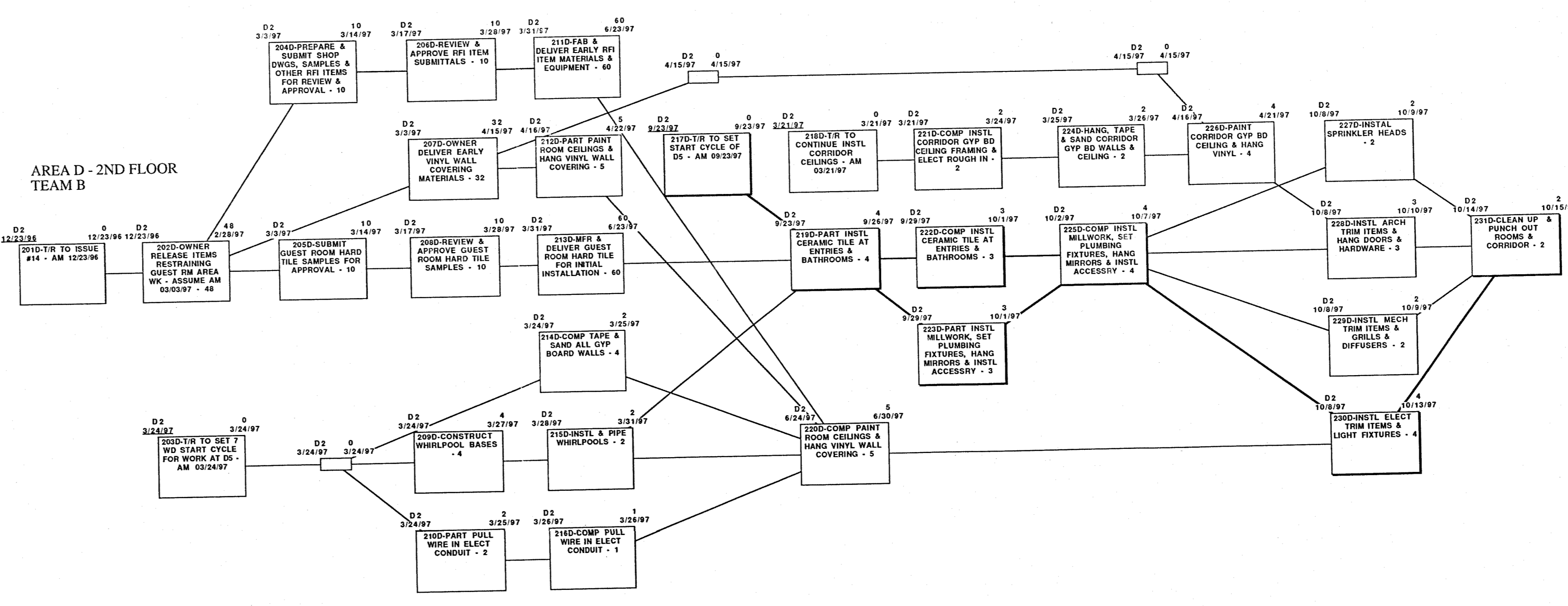

Note: This network model is based on two crews working one shift, 3 days 1st week and 8 hours per day. Non working days include Saturdays and Sundays, and September 1, 1995, November 23 - 25, December 25, 1996, January 1, 1996, May 27, 1996, July 4, 1996, September 2, 1996, November 28, 1996, December 25, 1996, January 1, 1997, May 26, 1997, July 4, 1997, September 1, 1997, November 23, 1997, and December 25, 1997.

Float time shown in this network model is for the sole use of Perini Building Company, U.S. Central District and is not to be used by others unless specifically approved in writing by Perini.

This network model has been prepared from information available to Perini/Shingobee as of December 27, 1996. As the project proceeds and additional information becomes available the network models and schedules may require revisions and updates. When this is necessary Perini/Shingobee will, with the cooperation of its staff and subcontractors, and with the assistance of the owner, update the network models and schedules to reflect current available information.

ACTIVITY KEY

Issue #1 through #11 - not issued	241	246	291	296
Issue #12 - October 18, 1996	242	247	292	297
Issue #13 - December 20, 1996	243	248	293	298
Issue #14 - December 23, 1996	244	249	294	299
Issue #15 - #25-1a	245	250	295	300

HOTEL INTERIOR WORK FOR
GUEST FLOOR 2 - TEAM B

NETWORK MODEL FOR SOARING
EAGLE RESORT - Chippewa Indian
Tribe of Michigan - Mt. Pleasant,
Michigan

Perini Building Company
and Shingobee Builders
Southfield, Michigan

Ralph J. Stephenson, P.E., P.C.
Consulting Engineer
323 Huronville Drive
Mt. Pleasant, Michigan 48858
ph 517 772 2537

LAN 201
HAN 7
Reserved Activity Numbers

3RD FLOOR GUEST ROOMS
INTERIOR PLAN OF WORK

AREA A - 3RD FLOOR
TEAM A

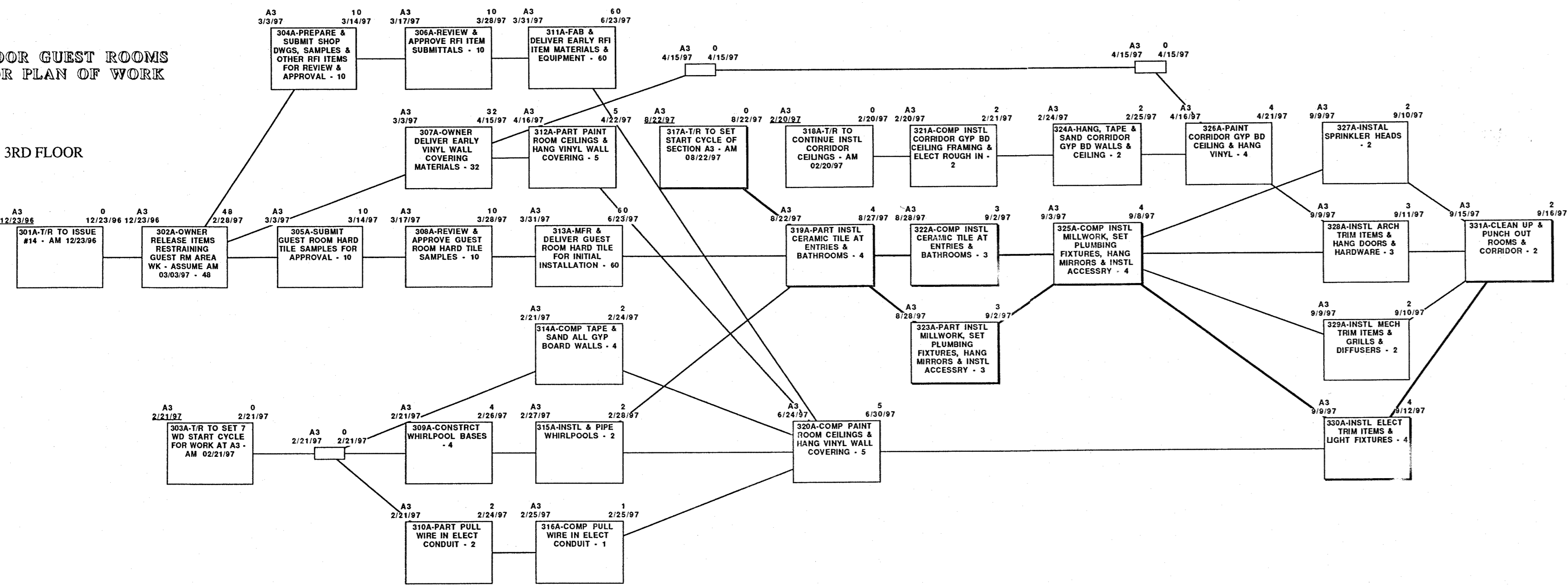

AREA B - 3RD FLOOR
TEAM A

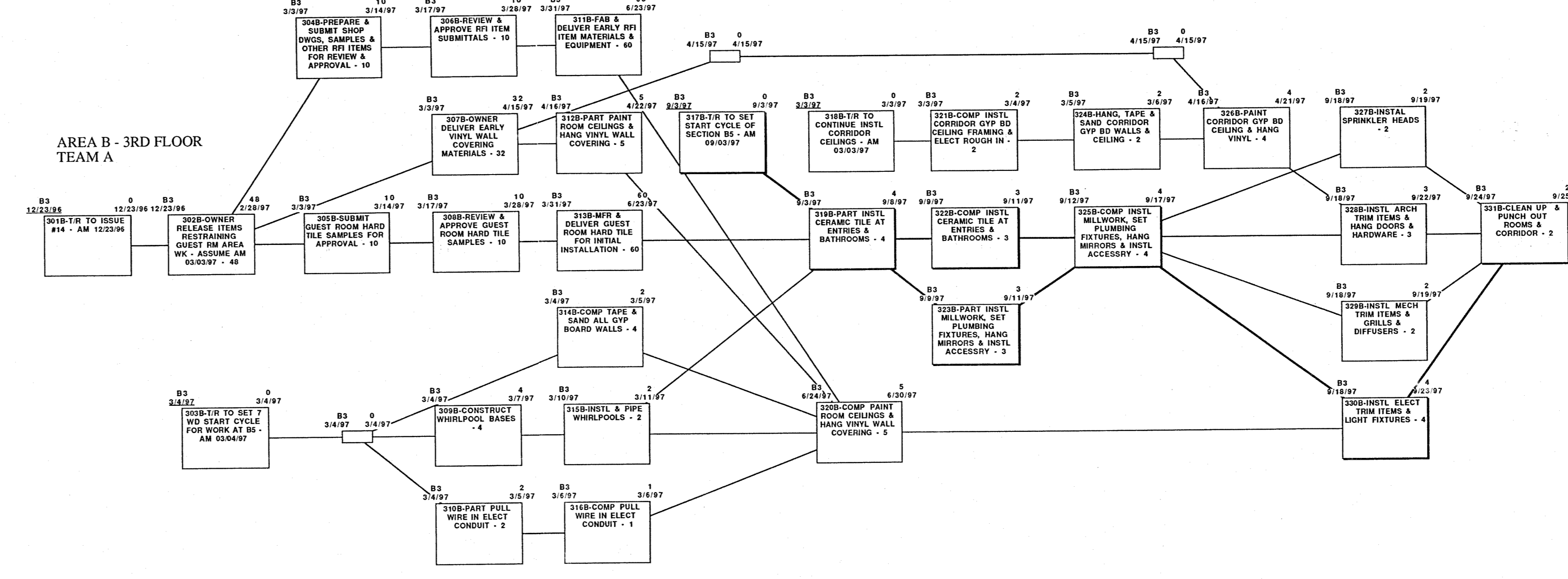

AREA C - 3RD FLOOR
TEAM A

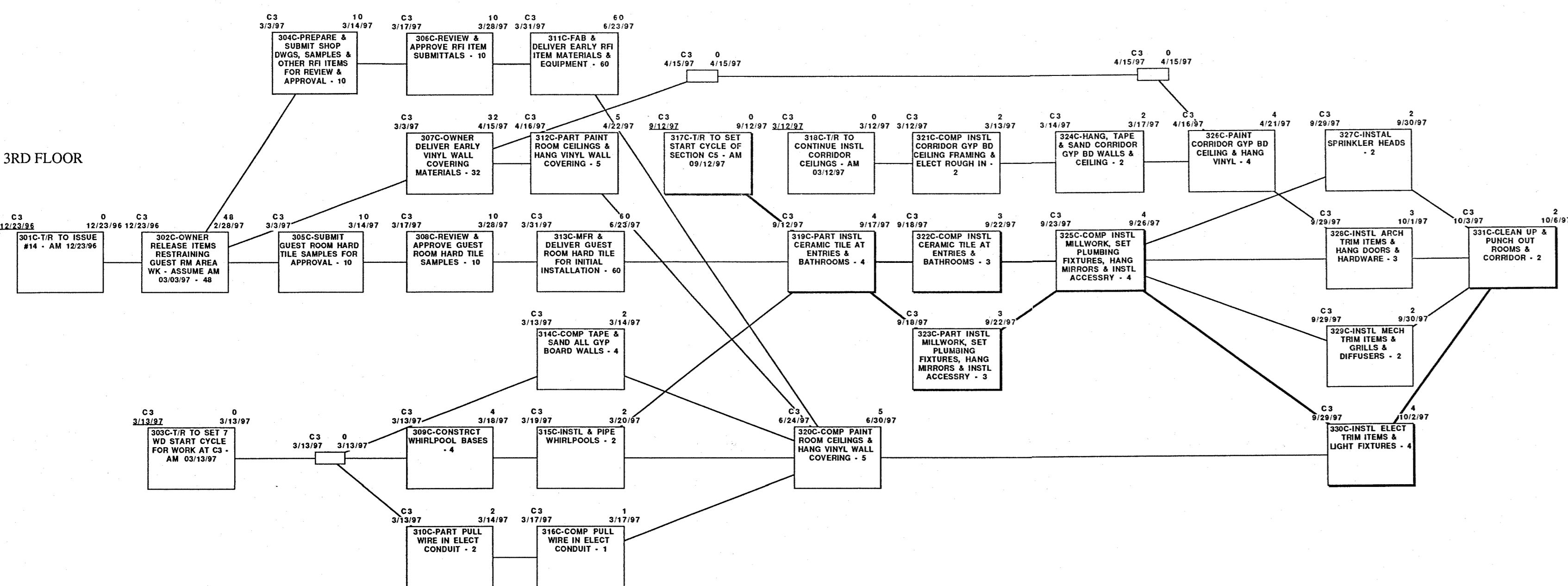

AREA D - 3RD FLOOR
TEAM A

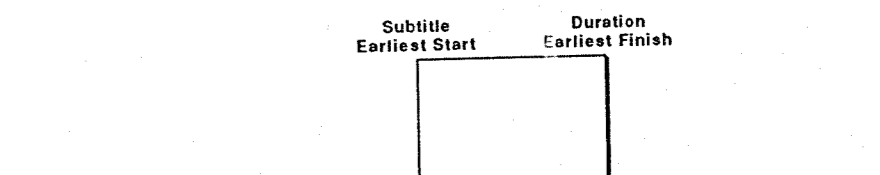
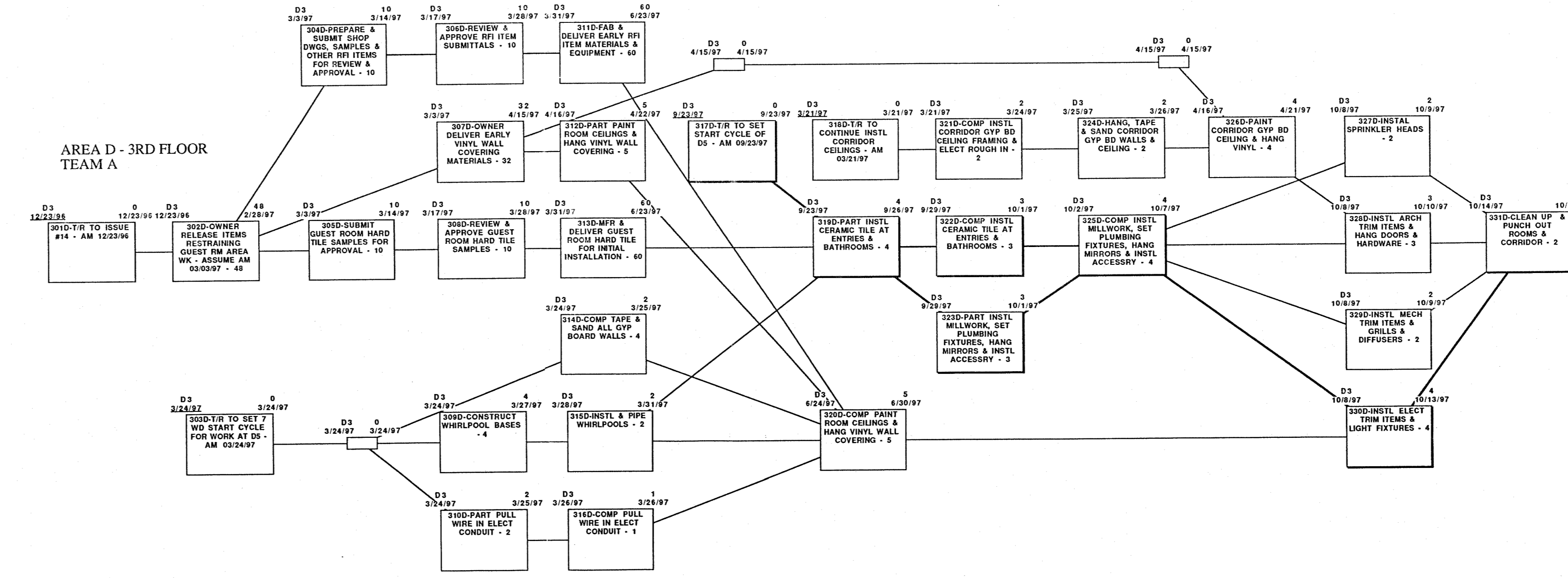

Note: This network model is based on two crews working one shift, 5 days per week and 8 hours per day. Non working days include Saturday and Sunday, and September 4, 1995, November 23, 1995, December 25, 1995, January 1, 1996, May 27, 1996, July 4, 1996, September 2, 1996, November 28, 1996, December 25, 1996, January 1, 1997, May 26, 1997, July 4, 1997, September 1, 1997, November 27, 1997, and December 25, 1997.

Plant time shown in this network model is for the sole use of Perini Building Company, U.S. Central District and is not to be used by others unless specifically approved in writing by Perini.

This network model has been prepared from information available to Perini/Shingobee as of December 27, 1996. As the project proceeds and additional information becomes available the network model and schedules may require revision and updating. When this is necessary Perini/Shingobee will, with the cooperation of its staff and subcontractors, and with the assistance of the owner, update the network model and schedule to reflect current available information.

ACTIVITY KEY
Issue #1 through 11 - not issued
Issue #12 - October 16, 1996
Issue #13 - December 28, 1996
Issue #14 - December 23, 1996
114 sht #G5-1a

**HOTEL INTERIOR WORK FOR
GUEST FLOOR 3 - TEAM A**

**NETWORK MODEL FOR SOARING
EAGLE RESORT - Chippewa Indian
Tribe of Michigan - Mt. Pleasant,
Michigan**

Perini Building Company
and Shingobee Builders
Southfield, Michigan

Ralph J. Stephenson, P.E., P.C.
Consulting Engineer
323 Hiawatha Drive
Mt. Pleasant, Michigan, 48858
ph 517 772 2537

**SHEET
#G5**

341	346	391	396
342	347	392	397
343	348	393	398
344	349	394	399
345	350	395	

Reserved Activity Numbers

4TH FLOOR GUEST ROOMS
INTERIOR PLAN OF WORK

AREA A - 4TH FLOOR
TEAM B

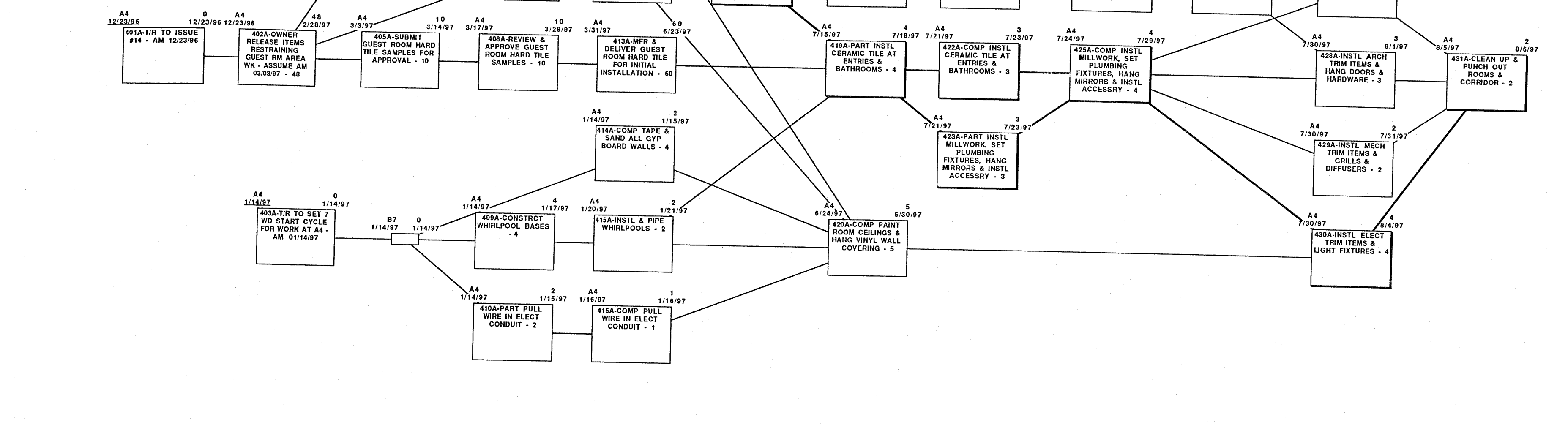

AREA B - 4TH FLOOR
TEAM B

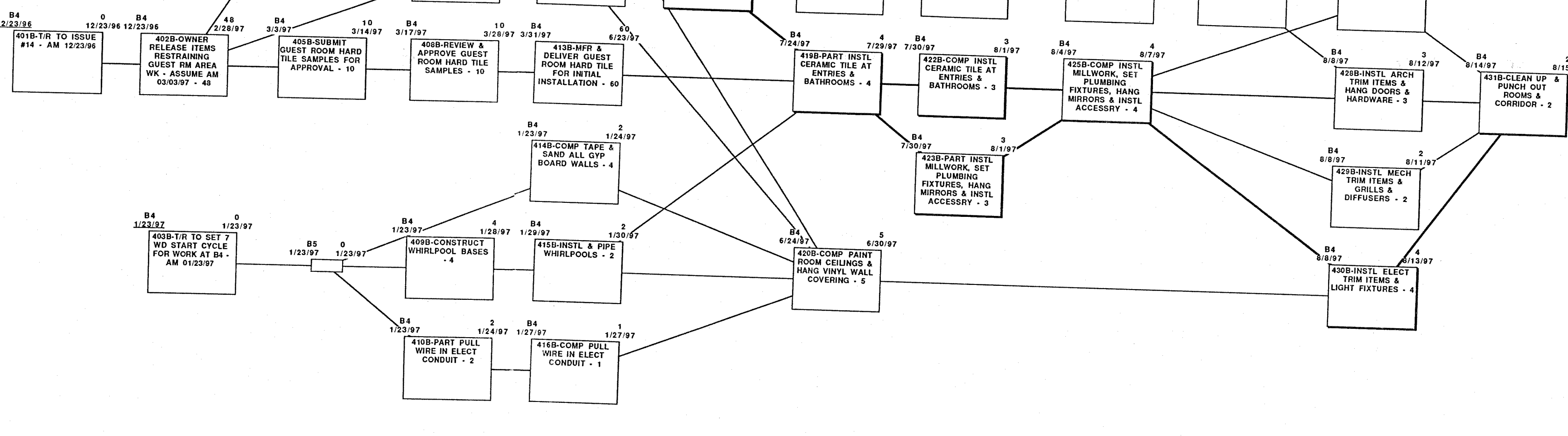

AREA C - 4TH FLOOR
TEAM B

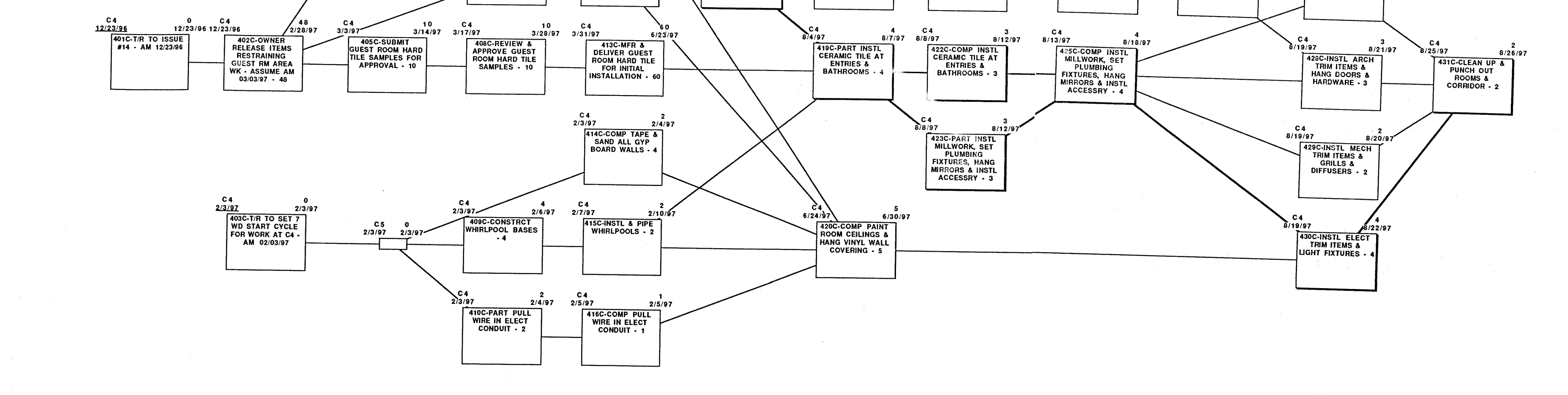

AREA D - 4TH FLOOR
TEAM B

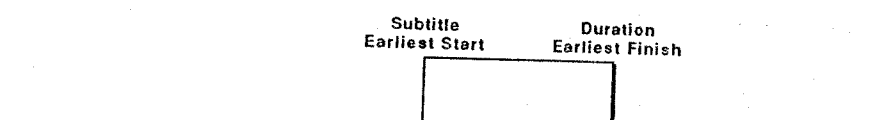
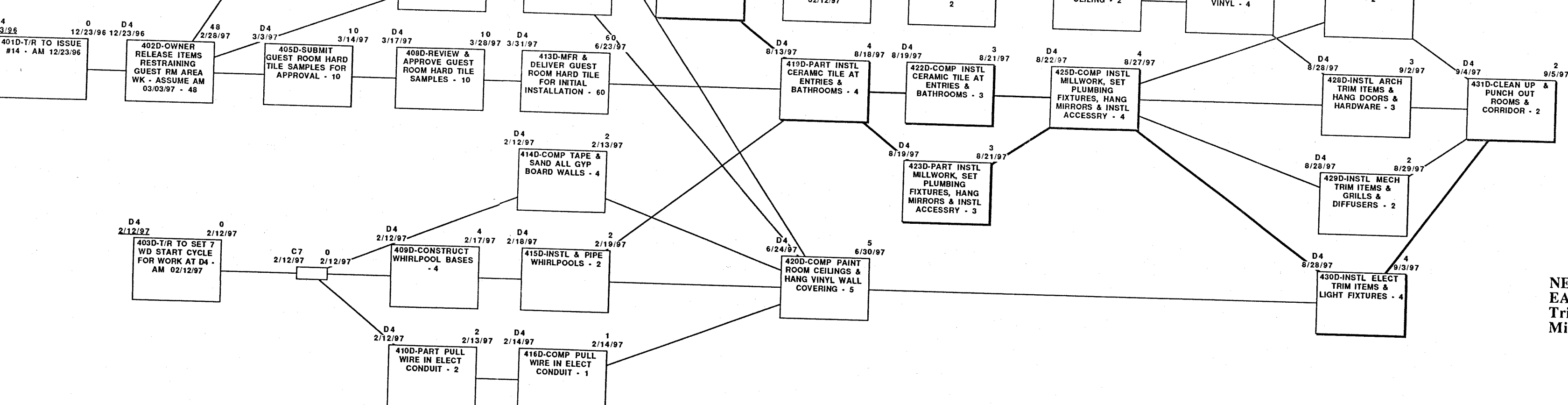

Note: This network model is based on two crews working one shift, 5 days per week and 8 hours per day. Non working days include Sunday and Monday, and September 4, 1996, November 23, 1996, December 25, 1996, January 1, 1997, May 27, 1996, July 4, 1996, September 2, 1996, November 28, 1996, December 25, 1996, January 1, 1997, May 26, 1997, July 4, 1997, September 1, 1997, November 27, 1997, and December 25, 1997. Float time shown in this network model is for the sole use of Perini Building Company, U.S. Central District and is not to be used by others unless specifically approved in writing by Perini.

This network model has been prepared from information available to Perini/Shingobee as of December 21, 1996. As the project proceeds and additional information becomes available the network models and schedules may require revisions and updates. When this is necessary Perini/Shingobee will, with the cooperation of its staff and subcontractors, and with the assistance of the owner, update the network models and schedules to reflect current available information.

ACTIVITY KEY

Issue #1 through #11 - not issued
Issue #12 - October 18, 1996
Issue #13 - December 26, 1996
Issue #14 - December 25, 1996
Issue #14 SH #24-1a

HOTEL INTERIOR WORK FOR
GUEST FLOOR 4 - TEAM B

NETWORK MODEL FOR SOARING
EAGLE RESORT - Chippewa Indian
Tribe of Michigan - Mt. Pleasant,
Michigan

Perini Building Company
and Shingobee Builders
Southfield, Michigan

441 446 491 496
442 447 492 497
443 448 493 498
444 449 494 499
445 450 495 495

LAN 401
HAN ?

Reserved Activity Numbers

Ralph J. Stephenson, P.E., P.C.
Consulting Engineer
325 Hiawatha Drive
Mt. Pleasant, Michigan, 48858
ph 517 772 2537

SHEET
#G4

LOBBY AREA
INCLUDES:
• Lounge
• Grand lobby
• Corridor to restaurants
• Grand stair
• Restaurant
• Lobby bar
• Elevator lobby 1140
• Elevator lobby 1080b
• Elevator lobby 1051
• Wine tasting
• Corridor to pool

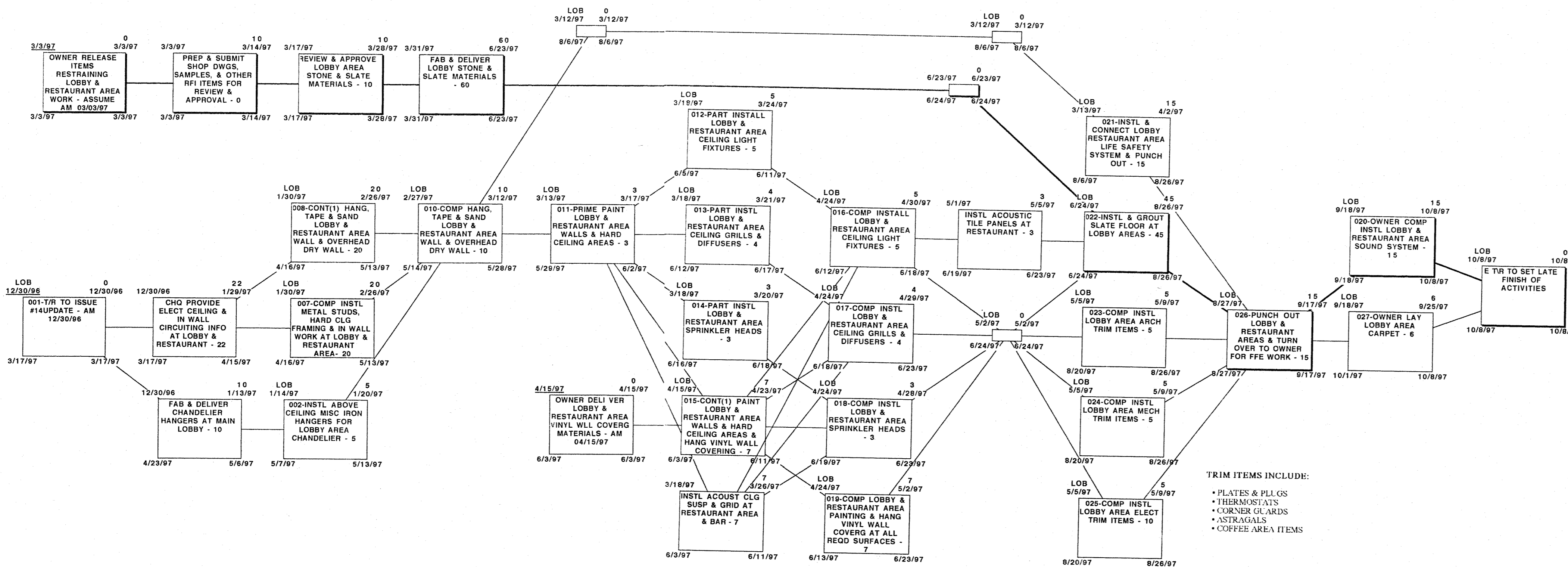

Note: This network model is based on one shift working 5 days per week and 8 hours per day. Non working days include Saturdays, Sundays, and September 4, 1995, November 23, 1995, December 25, 1995, January 1, 1996, May 27, 1996, July 4, 1996, September 2, 1996, November 28, 1996, and December 25, 1996.
Float time shown in this network model is for the sole use of Perini Building Company, U.S. Central District and is not to be used by others unless specifically approved in writing by Perini.

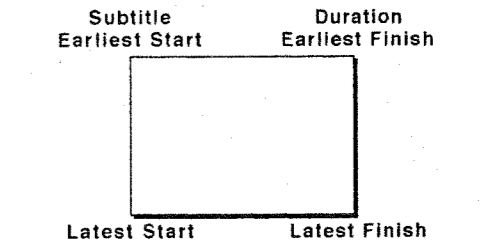

ACTIVITY KEY

Items to be resolved at lobby & restaurant area as of December 30, 1996

- #44 (NEED) Reflected ceiling plans for lobby
- #59 (NEED) Room finish schedule
- #17 (NEED) Design documents for lighting controls
- #45 (NEED) Lighting circuitry
- #60 (NEED) Construction documents for floor and millwork
- #07 (NEED) Design of grand fireplace
- #01 (NEED) Door and hardware schedules
- #?? Bronze door details - have block out info doors will be here March 15, 1997
- #?? Chandelier supports - on job by January 10, 1997
- #?? (NEED) Wood floor emblem for grand foyer
- #?? (NEED) Marble floor emblem

- Issue #1 through 7 - not issued
- Issue #8 - February 29, 1996
- Issue #9 - June 27, 1996
- Issue #9 - monitored 08/29/96
- Issue #10 - September 16, 1996
- Issue #10 - monitored 11/11/96
- Issues #11 to 13 - not used
- Issue #14 - December 23, 1996
- i14 sht #LOB 1 mtr 11/11/96

LOBBY & RESTAURANT AREA 1ST FLOOR INTERIOR NETWORK

NETWORK MODEL FOR SOARING EAGLE RESORT - Chippewa Indian Tribe of Michigan - Mt. Pleasant, Michigan

Perini Building Company and Shingobee Builders Southfield, Michigan

Ralph J. Stephenson, P.E., P.C.
Consulting Engineer
323 Hiawatha Drive
Mt. Pleasant, Michigan, 48858
ph 517 772 2537

Reserved Activity Numbers

041	046	091	096
042	047	092	097
043	048	093	098
044	049	094	099
045	050	095	100

LAN 001
HAN ?

SHEET #LOB1

ADMINISTRATIVE AREA INCLUDES:

- General offices
- Adjusting toilet rooms
- Front desk area
- Baggage storage areas
- Board room & pantry
- Waiting room
- Working conference room
- Reservation room
- Computer room

DECISION ITEMS

- INTERIM CONSTRUCTION TRAFFIC PLAN AT LOBBY

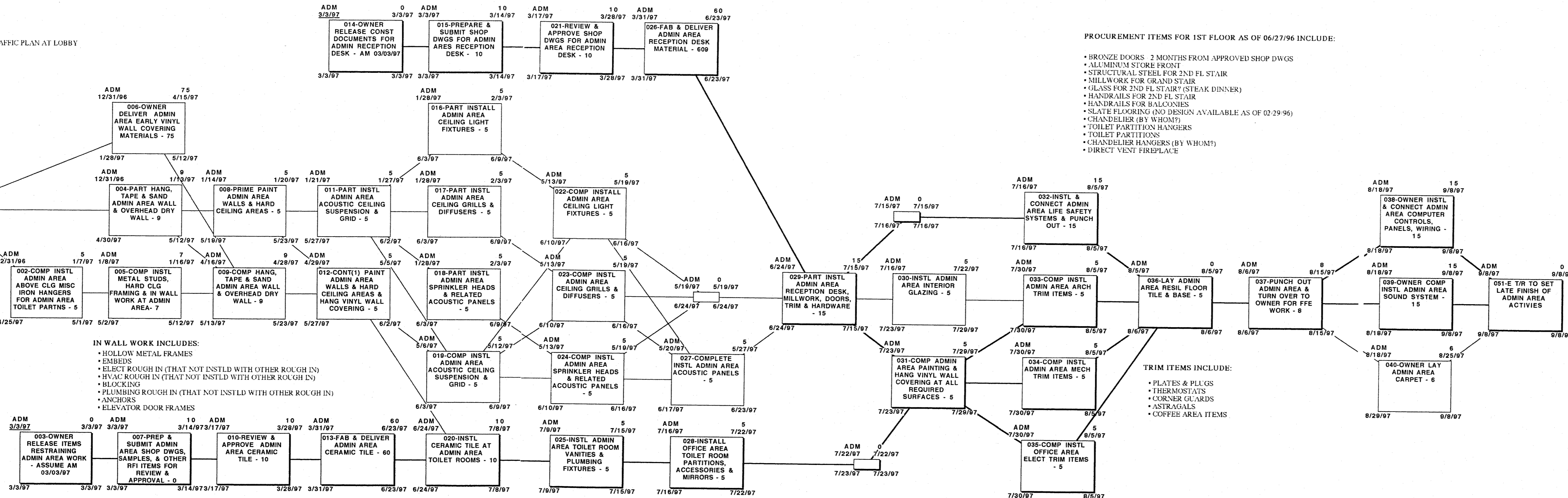

PROCUREMENT ITEMS FOR 1ST FLOOR AS OF 06/27/96 INCLUDE:

- BRONZE DOORS - 2 MONTHS FROM APPROVED SHOP DWGS
- ALUMINUM STORE FRONT
- STRUCTURAL STEEL FOR 2ND FL STAIR
- MILLWORK FOR GRAND STAIR
- GLASS FOR 2ND FL STAIR (STEAK DINNER)
- HANDRAILS FOR 2ND FL STAIR
- HANDRAILS FOR BALCONIES
- SLATE FLOORING (NO DESIGN AVAILABLE AS OF 02/29/96)
- CHANDELIER (BY WHOM?)
- TOILET PARTITION HANGERS
- TOILET PARTITIONS
- CHANDELIER HANGERS (BY WHOM?)
- DIRECT VENT FIREPLACE

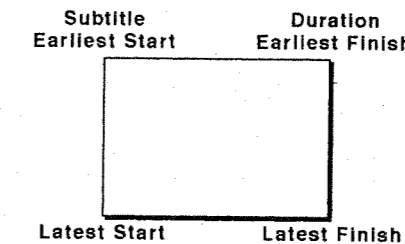

ACTIVITY KEY

Issue #1 through 7 not issued
 Issue #8 February 29, 1996
 Issue #9 June 27, 1996
 Issue #9 monitored 08/29/96
 Issue #10 September 10, 1996
 Issue #10 monitored 11/11/96
 Issues #11, 12 & 13 not used
 Issue #14 December 31, 1996
 i14 sht #AD1

Note: This network model is based on two crews working one shift, 5 days per week and 8 hours per day. Non working days include Saturdays, Sundays and September 4, 1995, November 23, 1995, December 25, 1995, January 1, 1996, May 27, 1996, July 4, 1996, September 2, 1996, November 28, 1996, December 25, 1996, January 1, 1997, May 26, 1997, July 4, 1997, September 1, 1997, November 27, 1997, and December 25, 1997.

Float time shown in this network model is for the sole use of Perini Building Company, U.S. Central District and is not to be used by others unless specifically approved in writing by Perini.

This network model has been prepared from information available to Perini/Shingobee as of December 27, 1996. As the project proceeds and additional information becomes available the network models and schedules may require revisions and updating. When this is necessary Perini/Shingobee will, with the cooperation of its staff and subcontractors, and with the assistance of the owner, update the network models and schedules to reflect current available information.

- IN WALL WORK INCLUDES:**
- HOLLOW METAL FRAMES
 - EMBEDS
 - ELECT ROUGH IN (THAT NOT INSTLD WITH OTHER ROUGH IN)
 - HVAC ROUGH IN (THAT NOT INSTLD WITH OTHER ROUGH IN)
 - BLOCKING
 - PLUMBING ROUGH IN (THAT NOT INSTLD WITH OTHER ROUGH IN)
 - ANCHORS
 - ELEVATOR DOOR FRAMES

- TRIM ITEMS INCLUDE:**
- PLATES & PLUGS
 - THERMOSTATS
 - CORNER GUARDS
 - ASTRAGALS
 - COFFEE AREA ITEMS

Reserved Activity Numbers

041	046	091	096
042	047	092	097
043	048	093	098
044	049	094	099
045	050	095	100

LAN 001
 HAN 1

1ST FLOOR ADMINISTRATIVE AREA INTERIOR NETWORK

NETWORK MODEL FOR SOARING EAGLE RESORT - Chippewa Indian Tribe of Michigan - Mt. Pleasant, Michigan

Perini Building Company and Shingobee Builders Southfield, Michigan

Ralph J. Stephenson, P.E., P.C.
 Consulting Engineer
 323 Hiawatha Drive
 Mt. Pleasant, Michigan, 48858
 ph 517 772 2537

- CONVENTION CENTER AREA INCLUDES
- Pre function area
 - Small meeting rooms
 - Toilet rooms
 - Ballroom
 - Vestibules (at least 4)
 - Board room & pantry
 - Entry foyer
 - Phone rooms
 - Coat rooms
 - Beverage area
 - Service corridors
 - Ballroom storage
 - Misc storage (at least 6)
 - Telephone equip room
 - Switchgear equip room
 - Fire pump equip room
 - Dishwashing room
 - Water equipment room
 - Loading dock area
 - Recycle room
 - Cable tv room
 - Service elevator lobby
 - Mezzanine access
 - Equipment mezzanine
 - Stair
 - Related offices (at least 5)

TODO

- CHANDELIERS
- MISC NON HANGERS
- FOLDING PARTITIONS
- CHECK GAMER ON BALLROOM TRUSSES - FOLDING PARTITION

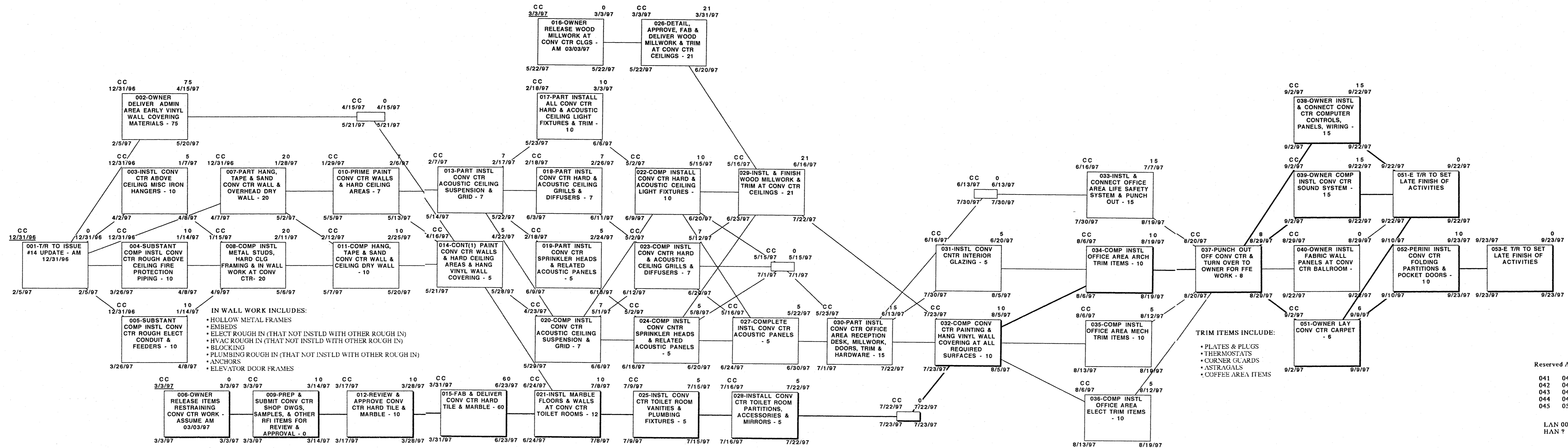

Note: This network model is based on two crews working one shift, 5 days per week and 8 hours per day. Non working days include Saturdays, Sundays, and September 4, 1995, November 23, 1995, December 25, 1995, January 1, 1996, May 27, 1996, July 4, 1996, September 2, 1996, November 28, 1996, December 25, 1996, January 1, 1997, May 26, 1997, July 4, 1997, September 1, 1997, November 27, 1997, and December 25, 1997.

Float time shown in this network model is for the sole use of Perini Building Company, U.S. Central District and is not to be used by others unless specifically approved in writing by Perini.

This network model has been prepared from information available to Perini-Shingobee as of December 27, 1996. As the project proceeds and additional information becomes available the network models and schedules may require revisions and updating. When this is necessary Perini-Shingobee will, with the cooperation of its staff and subcontractors, and with the assistance of the owner, update the network models and schedules to reflect current available information.

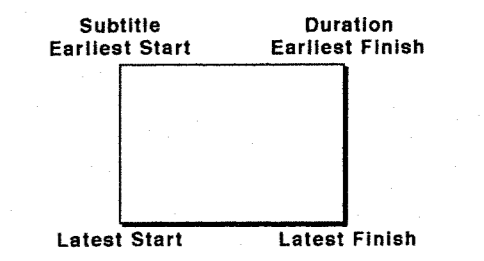

ACTIVITY KEY

Issues #1 through #13 - not used
Issue #14 - December 31, 1996
114 sht #CC1

CONVENTION CENTER INTERIOR NETWORK

NETWORK MODEL FOR SOARING EAGLE RESORT - Chippewa Indian Tribe of Michigan - Mt. Pleasant, Michigan

Perini Building Company and Shingobee Builders Southfield, Michigan

Ralph J. Stephenson, P.E., P.C.
Consulting Engineer
323 Hiawatha Drive
Mt. Pleasant, Michigan, 48858
ph 517 772 2537

Reserved Activity Numbers

041	046	091	096
042	047	092	097
043	048	093	098
044	049	094	099
045	050	095	100

LAN 001
HAN ?

AREA A1 - PERSONNEL AREA

- PERSONNEL AREA 1A INCLUDES:
- General offices
 - Adjoining toilet rooms
 - Locker rooms
 - Security room
 - Associate dining area
 - Food service area
 - Food service office
 - Private dining
 - Waiting
 - Pantry
 - Dishwashing
 - Storage
 - Coolers
 - Vestibule

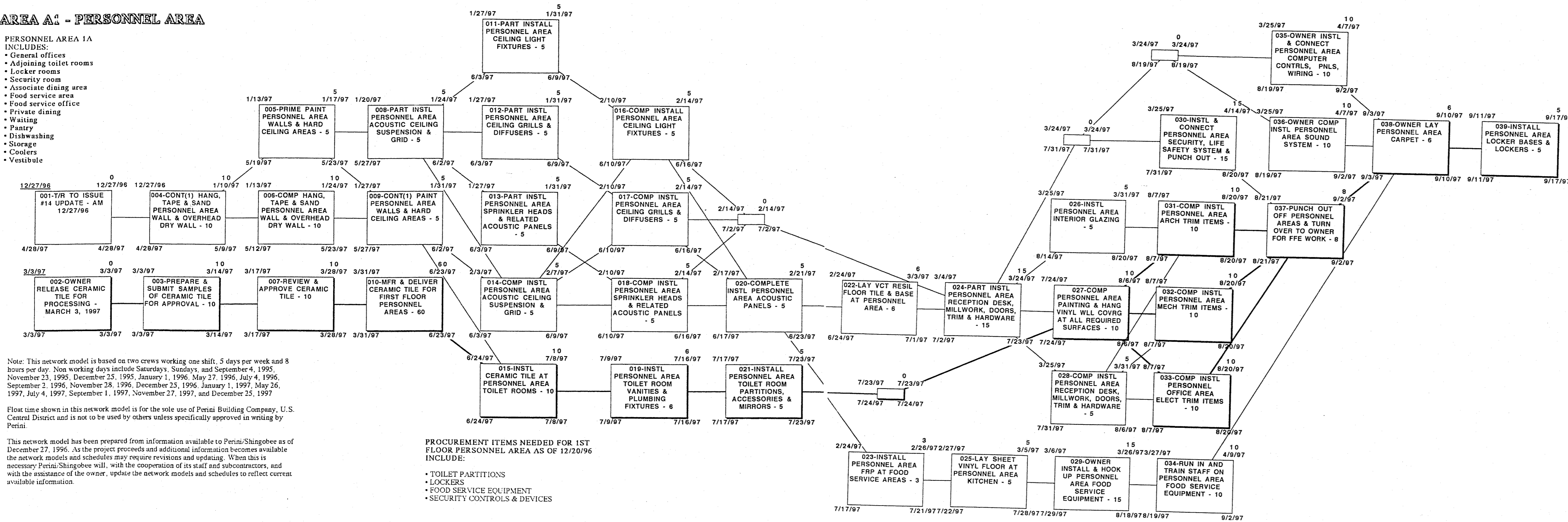

Note: This network model is based on two crews working one shift, 5 days per week and 8 hours per day. Non working days include Saturdays, Sundays, and September 4, 1995, November 23, 1995, December 25, 1995, January 1, 1996, May 27, 1996, July 4, 1996, September 2, 1996, November 28, 1996, December 25, 1996, January 1, 1997, May 26, 1997, July 4, 1997, September 1, 1997, November 27, 1997, and December 25, 1997.

Float time shown in this network model is for the sole use of Perini Building Company, U.S. Central District and is not to be used by others unless specifically approved in writing by Perini.

This network model has been prepared from information available to Perini/Shingobee as of December 27, 1996. As the project proceeds and additional information becomes available the network models and schedules may require revisions and updating. When this is necessary Perini/Shingobee will, with the cooperation of its staff and subcontractors, and with the assistance of the owner, update the network models and schedules to reflect current available information.

- PROCUREMENT ITEMS NEEDED FOR 1ST FLOOR PERSONNEL AREA AS OF 12/20/96 INCLUDE:
- TOILET PARTITIONS
 - LOCKERS
 - FOOD SERVICE EQUIPMENT
 - SECURITY CONTROLS & DEVICES

- Reserved Activity Numbers
- 046 091 096
 - 047 092 097
 - 048 093 098
 - 049 094 099
 - 050 095 100
- LAN 001
HAN 045
- Issue #1 through 7 - not issued
Issue #8 - February 29, 1996
Issue #9 - June 27, 1996
Issue #9 - monitored 08/29/96
Issue #10 - September 10, 1996
Issue #10 - monitored 11/11/96
Issue #11 & #12 - not issued
Issue #13 - December 23, 1996
Issue #14 - December 27, 1996
114 sht #1A

- TRIM ITEMS INCLUDE:
- PLATES & PILLOS
 - THERMOSTATS
 - CORNER GUARDS
 - ASTRAGALS
 - COFFEE AREA ITEMS

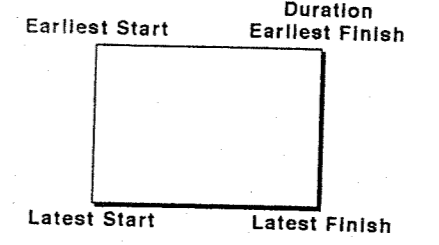

ACTIVITY KEY

1ST FLOOR AREA INTERIOR NETWORK - A1- PERSONNEL OFFICE

NETWORK MODEL FOR SOARING EAGLE RESORT - Chippewa Indian Tribe of Michigan - Mt. Pleasant, Michigan

Perini Building Company and Shingobee Builders
Southfield, Michigan

Ralph J. Stephenson, P.E., P.C.
Consulting Engineer
323 Hiawatha Drive
Mt. Pleasant, Michigan, 48858
ph 517 772 2537

PLAN OF WORK USING ONE TEAM OF FINISH TRADES WORKERS.

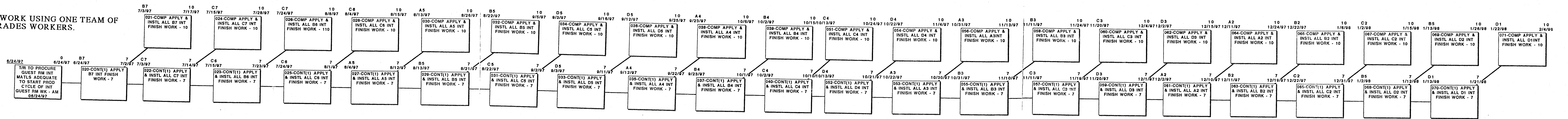

Guest room interior work sequence as of 10/18/96

- * B2 to B3 to B4 to B5 to B6 to B7 for remainder of gyp board work. (up)
- * B7 to C7 to B6 to C6 to A5 to B5 to C5 to D5 to A4 to B4 to C4 to D4 to A3 to B3 to C3 to C3 to A2 to B2 to C2 to D2 for remainder of interior finish work. (down)

PLAN OF WORK USING TWO TEAMS OF FINISH TRADES WORKERS.

- TEAM A FROM B7 C7 A5 B5 C5 D5 A3 B3 C3 D3 D1
- TEAM B FROM B6 C6 A4 B4 C4 D4 A2 B2 C2 D2

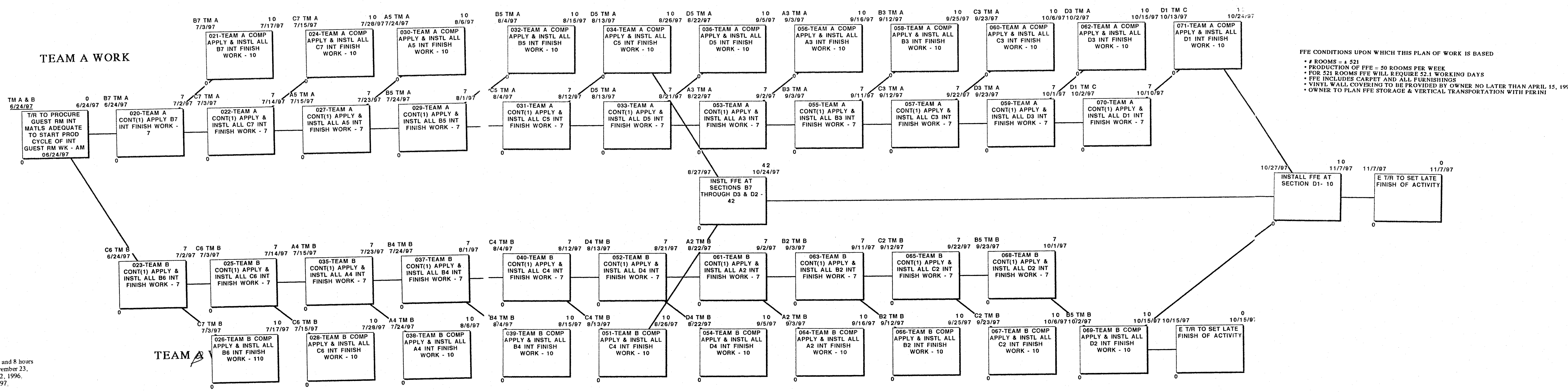

FFE CONDITIONS UPON WHICH THIS PLAN OF WORK IS BASED

- # ROOMS - 4 S21
- PRODUCTION OF FFE = 50 ROOMS PER WEEK
- FOR 521 ROOMS FFE WILL REQUIRE 52.1 WORKING DAYS
- FFE INCLUDES CARPET AND ALL FURNISHINGS
- VINYL WALL COVERING TO BE PROVIDED BY OWNER NO LATER THAN APRIL 15, 1997
- OWNER TO PLAN FFE STORAGE & VERTICAL TRANSPORTATION WITH PERINI

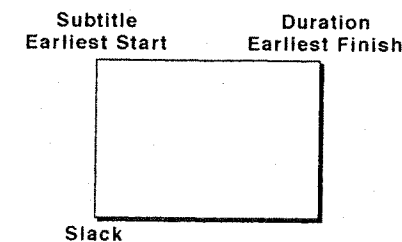

ACTIVITY KEY

Issue #1 through 10 not issued
 Issue #11 October 15, 1996
 Issue #12 October 19, 1996
 Issue #13 December 27, 1996 not issued
 used for internal review of assumptions
 Issue #14 December 27, 1996
 i14 sht SM1

SUMMARY MODEL FOR GUEST ROOM INTERIOR WORK - FLOORS 1 THROUGH 7

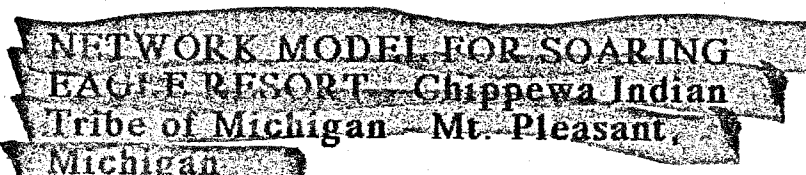

Reserved Activity Numbers

041	046	091	096
042	047	092	097
043	048	093	098
044	049	094	099
045	050	095	100

Perini Building Company and Shingobee Builders
 Southfield, Michigan

Ralph J. Stephenson, P.E., P.C.
 Consulting Engineer
 323 Hiawatha Drive
 Mt. Pleasant, Michigan, 48858
 ph 517 772 2537

SHEET SM1

Note: This network model is based on two crews working one shift, 5 days per week and 8 hours per day. Non working days include Saturdays, Sundays, and September 4, 1995, November 23, 1995, December 25, 1995, January 1, 1996, May 27, 1996, July 4, 1996, September 2, 1996, November 28, 1996, December 25, 1996, January 1, 1997, May 26, 1997, July 4, 1997, September 1, 1997, November 27, 1997, and December 25, 1997.

Flow time shown in this network model is for the sole use of Perini Building Company, U.S. Central District and is not to be used by others unless specifically approved in writing by Perini.

This network model has been prepared from information available to Perini/Shingobee as of December 27, 1996. As the project proceeds and additional information becomes available the network models and schedules may require revisions and updating. When this is necessary Perini/Shingobee will, with the cooperation of its staff and subcontractors, and with the assistance of the owner, update the network models and schedules to reflect current available information.

1ST FLOOR GUEST ROOMS
INTERIOR PLAN OF WORK

AREA A - 1ST FLOOR
TEAM A

AREA D - 1ST FLOOR
TEAM A

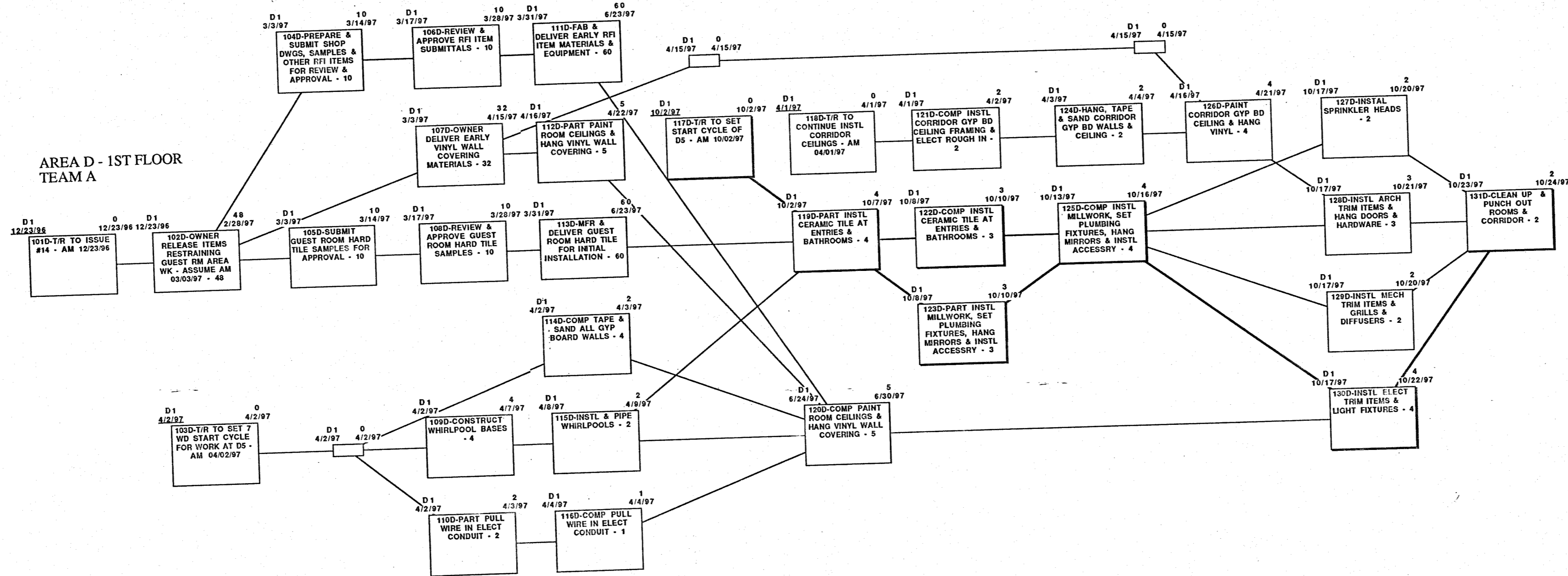

Note: This network model is based on two crews working one shift, 5 days per week and 8 hours per day. Non working days include Saturday and Sundays, and September 4, 1995, November 23, 1995, December 23, 1995, January 1, 1996, May 27, 1996, July 4, 1996, September 2, 1996, November 28, 1996, December 25, 1996, January 1, 1997, May 26, 1997, July 4, 1997, September 1, 1997, November 27, 1997, and December 25, 1997.

Float time shown in this network model is for the sole use of Perini Building Company, U.S. Central District and is not to be used by others unless specifically approved in writing by Perini.

This network model has been prepared from information available to Perini/Shingobee as of December 27, 1996. As the project proceeds and additional information becomes available the network models and schedules may require revisions and updating. When this is necessary Perini/Shingobee will, with the cooperation of its staff and subcontractors, and with the assistance of the owner, update the network models and schedules to reflect current available information.

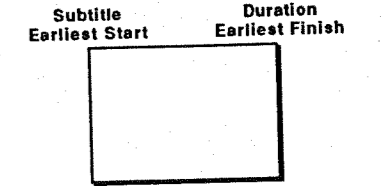

ACTIVITY KEY

Issue #1 through 11 - not issued
Issue #12 - October 18, 1996
Issue #13 - December 20, 1996
Issue #14 - December 23, 1996
114 sht #G7-la

HOTEL INTERIOR WORK FOR
GUEST FLOOR 1 - TEAM A

NETWORK MODEL FOR SOARING
EAGLE RESORT - Chippewa Indian
Tribe of Michigan - Mt. Pleasant,
Michigan

141	146	191	196
142	147	192	197
143	148	193	198
144	149	194	199
145	150	195	

LAN 101
HAN ?
Reserved Activity Numbers

Perini Building Company
and Shingobee Builders
Southfield, Michigan

Ralph J. Stephenson, P.E., P.C.
Consulting Engineer
323 Hiawatha Drive
Mt. Pleasant, Michigan, 48858
ph 517 772 2537

SHEET
#G7